

客户名称 CUSTOMER		客户料号 CUS. PART. NO		版次 REV:A 页码:
品名规格 ITEM SPECS	共模滤波器	料号 MD SKU. NO	UU9.8-10MH MIN 0.2	数量 Q' TY: R. H. 83% TEMP:23℃

1. 外观尺寸DIMENSIONS (UNIT:mm)

2. 电气原理图SCHEMATIC

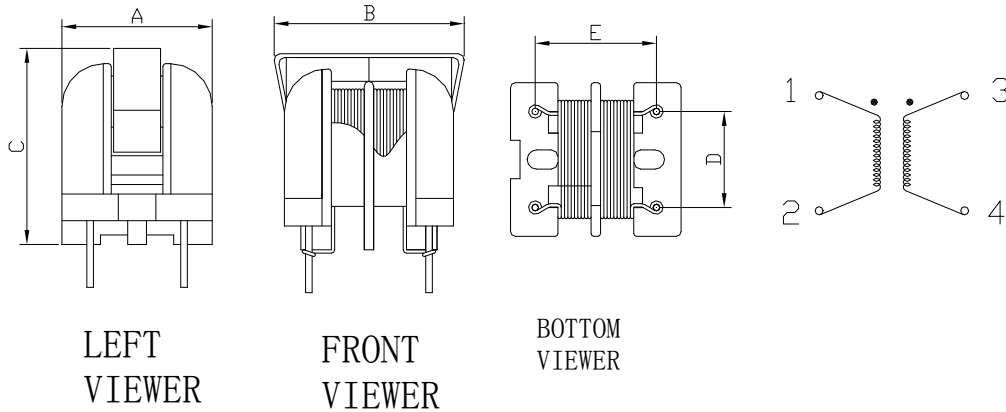

3. 线包结构图WINDING CONSTRUCTION:

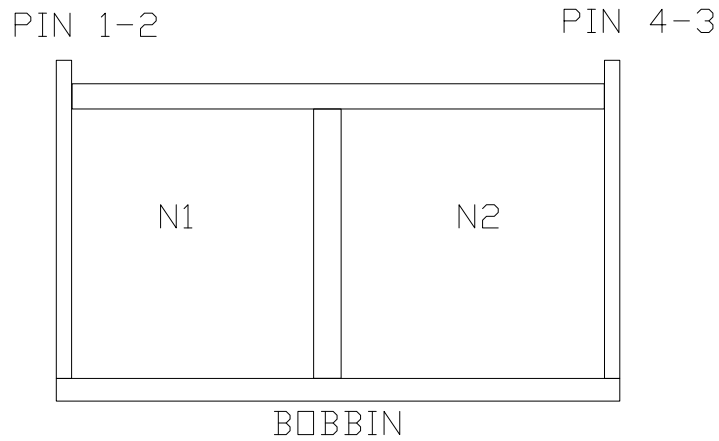

A	11.0MAX	E	8.0REF	I		N			
B	16MAX	F		J		O			
C	16.5MAX	G		K		P			
D	7.0REF	H		M		Q			
制作 (MADE BY)				审核 (CHECKEI BY)				核准 (APPROVED BY)	

客户名称 CUSTOMER		客户料号 CUS. PART. NO		版次 REV:A 页码: 数量 Q' TY:
品名规格 ITEM SPECS	共模滤波器	料号 MD SKU. NO	UU9.8-10MH MIN 0.2	R. H. 83% TEMP:23℃

4. :线圈绕制表WINDING:

绕组 Note	档墙 Insulated	脚位 Start	槽位 Slot	线径股数 Wire Type	圈数 Turns	绝缘层数 Tape	绕制方法 Winding method
N1	/	1--2	/	2UEW0.2*1P	75TS (ref)	/	双组并绕
N2	/	3--4	/	2UEW0.2*1P	75TS (ref)	/	

备注: 1. 绕制装夹放向PIN脚朝上, 双组并绕, 机器顺时针转动。
2. 产品以电感为准, 圈数可调。

5. 注意说明 (Remark)

1. 产品用UU9.8立式(2+2)双槽骨架。
2. PIN1-2电感为(10mH MIN-匝数为75TS),
PIN4-3电感为(10mH MIN-匝数为75TS)。
3. 组装: 镜面磁芯立式安装, 需用铁夹卡紧。
4. 浸油时注意PIN脚不能沾到油。

6. 物料清单 (Material List)

序号	物料名称 Name	规格描述 Spec	等级 Class	厂商 Supplier	备注
1	骨架 (BOBBIN)	UU9.8立式(2+2)	130℃	shenzhenxinfengjia	环保
2	磁芯 (CORE)	UU9.8	/	shenzhenxinfengjia	环保
3	铜线 (WIRE)	2UEW	155℃	qing yuan chang fa	环保
4		2UEW绞线	130℃	dong guan da chuang	环保
5					
7	套管 (TUBE)	PTFE TUBE	200℃	dong guan chang bo	环保
8	锡条 (SOLDER)	无铅锡条	/	dong guan hong xing wei	环保
9	绝缘漆 (VARNISH)	INSULATING PAINT THE THINNER MITURE	/	zhu hai fu er de	环保
10	环氧树脂 (EPOXY)	FK661	/	hui zhou qi fu	环保
制作 (MADE BY)			审核 (CHECKEI BY)		核准 (APPROVED BY)

客户名称 CUSTOMER		客户料号 CUS. PART. NO		版次 REV:A 页码: 数量 Q' TY:
品名规格 ITEM SPECS	共模滤波器	美登料号 MD SKU. NO	UU9.8-10MH MIN 0.2	R. H. 83% TEMP:23°C

7. 电气特性 (Electrical Characteristics)

序号 Ref. No	测试项目 Test Item	测试脚位 Test Pin	规格要求 Spec. Request	测试条件 Test Condition
①	电感 (L)	L (1--2)	10mH min	TH2817B 1KHZ 0.25V
		L (3--4)	10mH min	
②	内阻 (Ω)	Ω	1.2 Ω (Max)	TH2512A

8. 样品检验表 (Test Records)

MEAS	A (mm)	B (mm)	C (mm)	D (mm)	E (mm)	F (mm)	G (mm)	H (mm)	L (3--4)	L (1--2)	Ω
SPEC	11.0MAX	16MAX	16.5MAX	7.0REF	8.0REF	0	0	0	10mH min	10mH min	1.2 Ω (Max)
Su											
Sc											
1	10.68	15.50	16.05	7.03	7.99				28.06	28.05	0.948
2	10.69	15.63	16.03	7.12	7.95				26.56	26.55	0.893
3	10.76	15.55	16.00	7.06	7.96				22.15	22.11	0.972
4	10.82	15.58	15.96	7.10	7.99				26.25	26.22	0.953
5	10.74	15.54	15.97	7.07	7.99				21.36	21.34	0.944
6	10.68	15.50	16.05	7.03	7.99				22.08	22.12	0.926
7	10.69	15.63	16.03	7.12	7.95				18.39	18.42	0.895
8	10.76	15.55	16.00	7.06	7.96				19.66	19.67	0.956
9	10.82	15.58	15.96	7.10	7.99				20.54	20.55	0.952
10	10.74	15.54	15.97	7.07	7.99				26.41	26.43	0.933
MAX	10.82	15.63	16.05	7.12	7.99				28.06	28.05	0.972
MIN	10.68	15.50	15.96	7.03	7.95				18.39	18.42	0.893
R	0.14	0.13	0.09	0.09	0.04				9.67	9.63	0.079
X	10.74	15.56	16.00	7.08	7.98				23.15	23.15	0.937

制作 (MADE BY)		审核 (CHECKEI BY)		核准 (APPROVED BY)