

CUSTOMER : T16V02A

PART NO. : EF12.6

DATE :

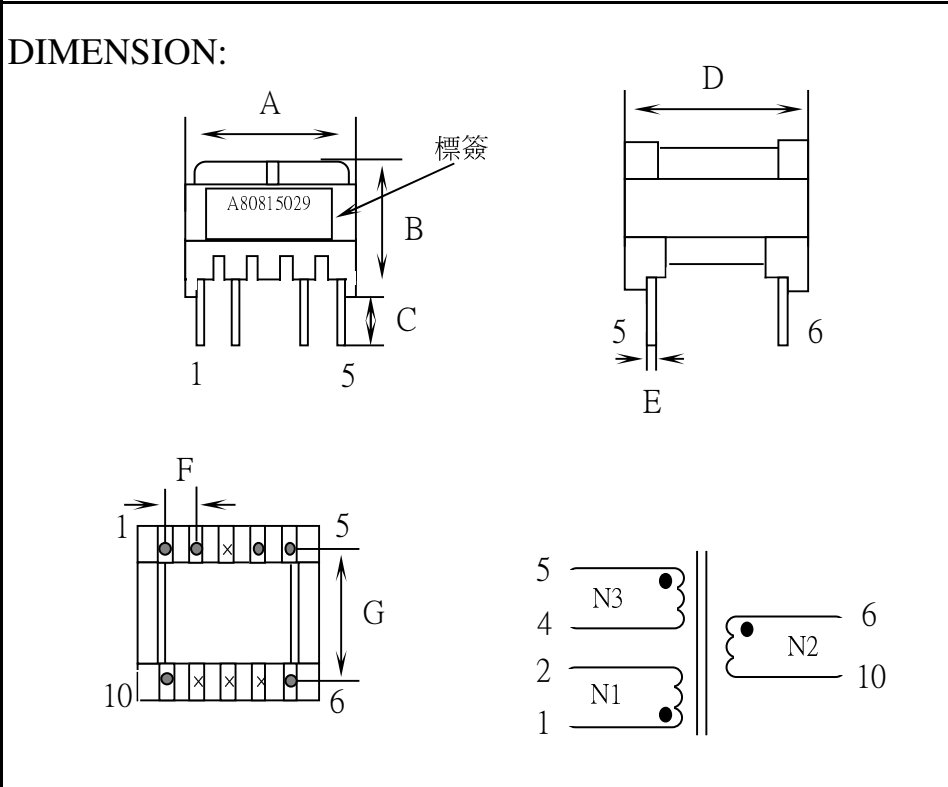

A	m/m
B	m/m
C	m/m
D	m/m
E	m/m
F	m/m
G	m/m
H	m/m
I	m/m
J	m/m
K	m/m

<i>ELECTRICAL REQUIREMENTS</i>		
L(1-2)	5±10%	m H
DCR(1-2)		OHM
DCR(6-10)		OHM
DCR(5-4)		OHM
/		
WIRE(1-2)	0.12	2UEW
WINDING(1-2)	320	TS
WIRE(6-10)	0.25	2UEW
WINDING(6-10)	50	TS
WIRE(5-4)	0.12	2UEW
WINDING(5-4)	64	TS

TEST INSTRUMENTS: CH1310 CH-102-LCR

TEST FREQUENCY : 1 KHZ / 1 V

EXPLANATION :

- PIN1朝外繞線正繞,PIN3.7.8.9CUT OFF
- 鐵芯外包2TS TAPE,CAP CORE
- HI-POT: PRI.-SEC. 1500Vac 5mA/3SEC.
PRI-CORE. 500Vac 5mA/3SEC.
SEC-CORE 500Vac 5mA/3SEC.
- MARKING:

T1202W11
CEC YY WW

 透明底黑字,字首朝PIN1.
- 產品須含浸.

<i>DRAWING BY</i>	<i>CHECKED BY</i>	<i>APPROVED BY</i>	<i>CUSTOMER APPROVAL</i>
-------------------	-------------------	--------------------	--------------------------