

DIRECTION OF ROTATION

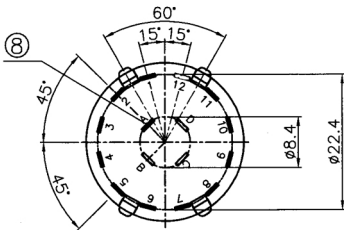

NUT 1PC

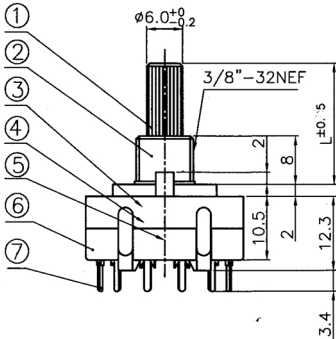
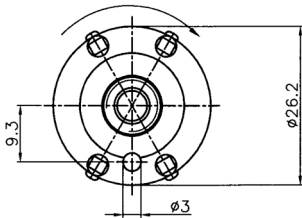
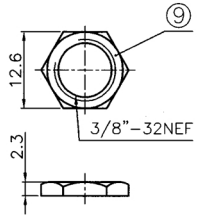

WASHER 1PC t=0.5

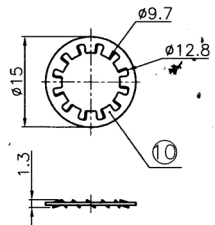

SCHEMATIC

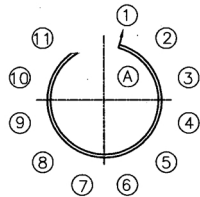

QTY	Part No	Description	Material	Finishing
1	W-3/8"	Washer	Stell t=0.5	Zinc Plating
1	N-3/8"	NUT	Stell t=2.3	Zinc Plating
1	SR26105-6	Internal terminal	Brass	Silver Plating
11	SR26105N	External terminal	Brass	Silver Plating
1	SR2611-4C	Element	NYLON+30%FB	No Plating
2	SR2527	Stell Ball	Stell	Silver Plating
1	SR2615	Spring	SWPA	Silver Plating
2	SR2606A	Contact Plate	Phosphor-bronze	Silver Plating
1	SR2609E-12	Case	NYLON+30%FB	No Plating
1	SR2601- K	Shaft	POM	No Plating

MODEL	L
35K	35
30K	30
25K	25
20K	20
15K	15