

## N-Channel Enhancement Mode Power MOSFET

# LUT6N65

<b><math>BV_{DSS}</math> : 650V</b> <b><math>R_{DS(ON)}</math> : 1.23 <math>\Omega</math> (typ.)</b> <b><math>I_D</math> : 6A</b>
---

### Description

The LUT6N65 is a N-channel enhancement-mode MOSFET, providing the designer with the best combination of fast switching, ruggedized device design, low on-resistance and cost effectiveness. The TO-220FP package is universally preferred for all commercial-industrial applications

### Features

- Low On Resistance
- Simple Drive Requirement
- Fast Switching Characteristic
- Insulating package, front/back side insulating voltage=2500V(AC)
- RoHS compliant package

### Applications

- Adapter
- Switching Mode Power Supply
- BLDC Motor Control Application

### Symbol

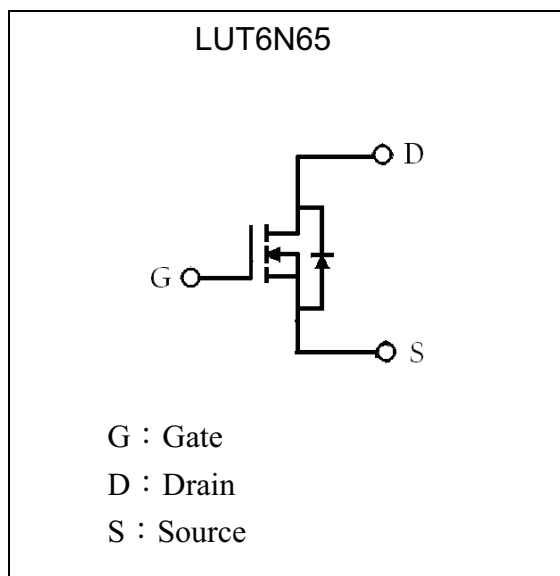

### Outline

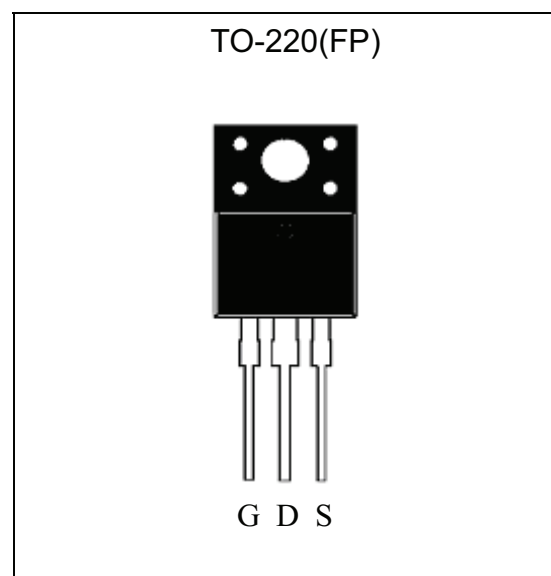

## Absolute Maximum Ratings (T<sub>C</sub>=25°C)

Parameter	Symbol	Limits	Unit
Drain-Source Voltage	V <sub>DS</sub>	650	V
Gate-Source Voltage	V <sub>GS</sub>	±30	V
Continuous Drain Current	I <sub>D</sub>	6*	A
Continuous Drain Current @T <sub>C</sub> =100°C	I <sub>D</sub>	3.6*	A
Pulsed Drain Current @ V <sub>GS</sub> =10V (Note 1)	I <sub>DM</sub>	24*	A
Single Pulse Avalanche Energy (Note 2)	E <sub>AS</sub>	135	mJ
Avalanche Current (Note 1)	I <sub>AR</sub>	6	A
Repetitive Avalanche Energy (Note 1)	E <sub>AR</sub>	5.4	mJ
Peak Diode Recovery dv/dt (Note 3)	dv/dt	4.5	V/ns
Maximum Temperature for Soldering @ Lead at 0.125 in(0.318mm) from case for 10 seconds	T <sub>L</sub>	300	°C
Total Power Dissipation (T <sub>C</sub> =25°C)	P <sub>D</sub>	54	W
Linear Derating Factor		0.3	W/°C
Operating Junction and Storage Temperature	T <sub>J</sub> , T <sub>stg</sub>	-55~+150	°C

\*Drain current limited by maximum junction temperature

Note : 1.Repetitive rating; pulse width limited by maximum junction temperature.

2. I<sub>AS</sub>=6A, V<sub>DD</sub>=50V, L=7mH, R<sub>G</sub>=25Ω, starting T<sub>J</sub>=+25°C.

3. I<sub>SD</sub>≤6A, dI/dt≤100A/μs, V<sub>DD</sub>≤BV<sub>DSS</sub>, starting T<sub>J</sub>=+25°C.

## Thermal Data

Parameter	Symbol	Value	Unit
Thermal Resistance, Junction-to-case, max	R <sub>th,j-c</sub>	2.3	°C/W
Thermal Resistance, Junction-to-ambient, max	R <sub>th,j-a</sub>	62.5	°C/W

## Characteristics (Tj=25°C, unless otherwise specified)

Symbol	Min.	Typ.	Max.	Unit	Test Conditions
<b>Static</b>					
BV <sub>DSS</sub>	650	-	-	V	V <sub>GS</sub> =0, I <sub>D</sub> =250μA, Tj=25°C
ΔBV <sub>DSS</sub> /ΔTj	-	0.65	-	V/°C	Reference to 25°C, I <sub>D</sub> =250μA
V <sub>GS(th)</sub>	2.0	-	4.0	V	V <sub>DS</sub> = V <sub>GS</sub> , I <sub>D</sub> =250μA
*G <sub>FS</sub>	-	3	-	S	V <sub>DS</sub> =15V, I <sub>D</sub> =3A
I <sub>GSS</sub>	-	-	±100	nA	V <sub>GS</sub> =±30
I <sub>DSS</sub>	-	-	1	μA	V <sub>DS</sub> =650V, V <sub>GS</sub> =0
	-	-	10		V <sub>DS</sub> =520V, V <sub>GS</sub> =0, Tj=125°C
*R <sub>DS(ON)</sub>	-	1.23	1.5	Ω	V <sub>GS</sub> =10V, I <sub>D</sub> =3A
<b>Dynamic</b>					
*Q <sub>g</sub>	-	19	-	nC	I <sub>D</sub> =6A, V <sub>DS</sub> =520V, V <sub>GS</sub> =10V
*Q <sub>gs</sub>	-	5.1	-		
*Q <sub>gd</sub>	-	6.9	-		
*t <sub>d(ON)</sub>	-	12	-	ns	V <sub>DS</sub> =325V, I <sub>D</sub> =6A, V <sub>GS</sub> =10V, R <sub>G</sub> =25Ω
*t <sub>r</sub>	-	13	-		
*t <sub>d(OFF)</sub>	-	25	-		
*t <sub>f</sub>	-	13	-		
C <sub>iss</sub>	-	1350	-	pF	V <sub>GS</sub> =0V, V <sub>DS</sub> =25V, f=1MHz
C <sub>oss</sub>	-	120	-		
C <sub>rss</sub>	-	26	-		
<b>Source-Drain Diode</b>					
*I <sub>S</sub>	-	-	6	A	
*I <sub>SM</sub>	-	-	24		
*V <sub>SD</sub>	-	-	1.5	V	I <sub>S</sub> =6A, V <sub>GS</sub> =0V
*t <sub>rr</sub>	-	330	-	ns	V <sub>GS</sub> =0, I <sub>F</sub> =6A, dI/dt=100A/μs
*Q <sub>rr</sub>	-	2.8	-	μC	

\*Pulse Test : Pulse Width ≤300μs, Duty Cycle≤2%

## Ordering Information

Device	Package	Shipping
LUT6N65	TO-220(FP) (RoHS compliant)	50 pcs/tube, 20 tubes/box, 4 boxes / carton

## Typical Characteristics

Typical Output Characteristics

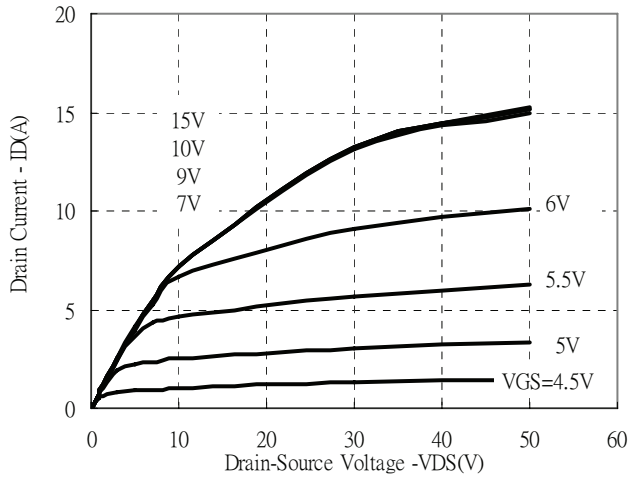

Static Drain-Source On-resistance vs Ambient Temperature

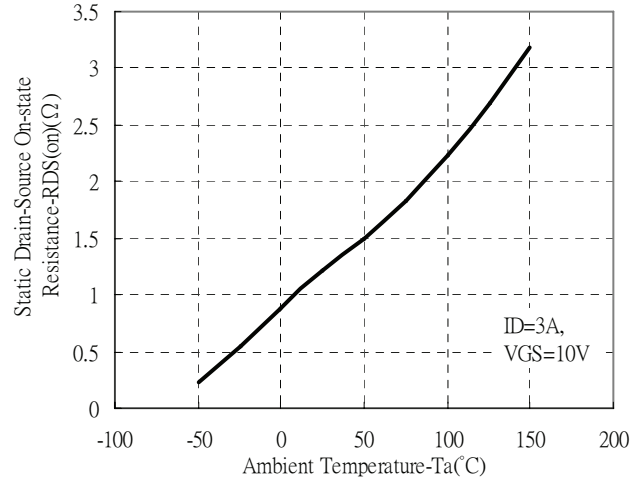

Static Drain-Source On-State resistance vs Drain Current

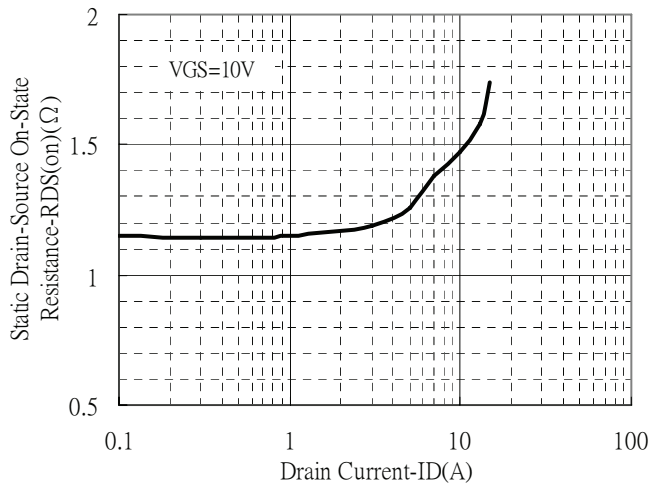

Drain Current vs Gate-Source Voltage

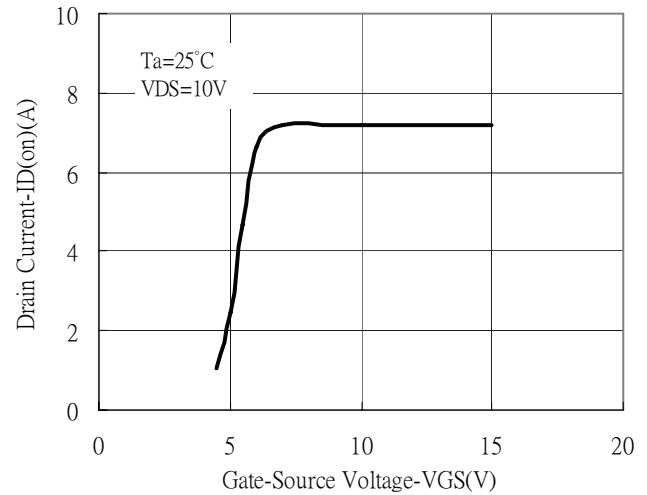

Static Drain-Source On-State Resistance vs Gate-Source Voltage

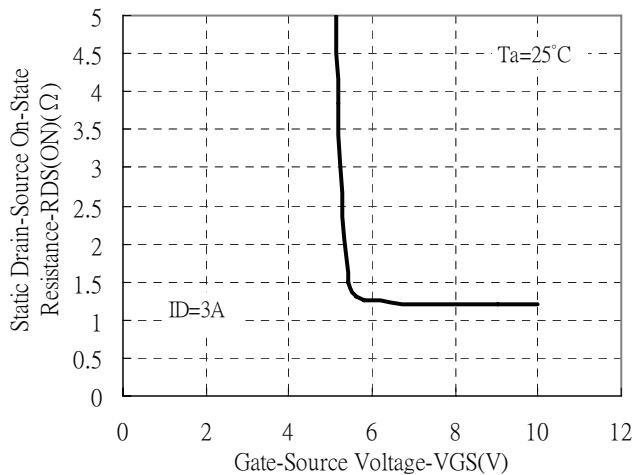

Forward Drain Current vs Source-Drain Voltage

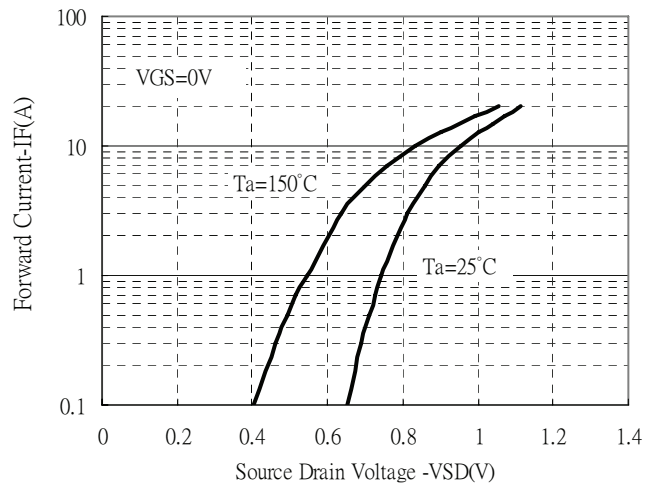

## Typical Characteristics(Cont.)

Capacitance vs Reverse Voltage

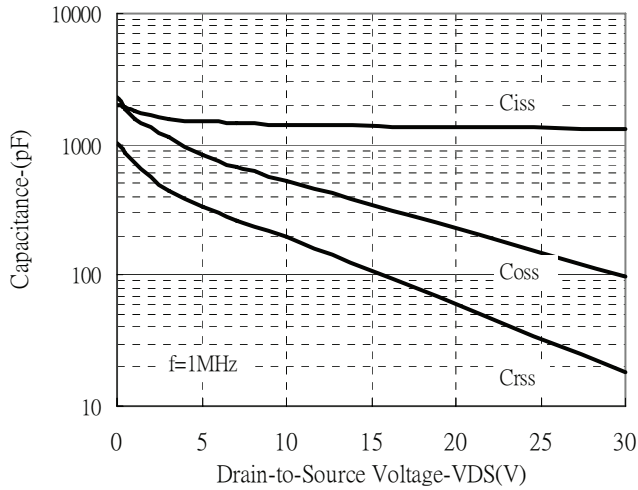

Breakdown Voltage vs Ambient Temperature

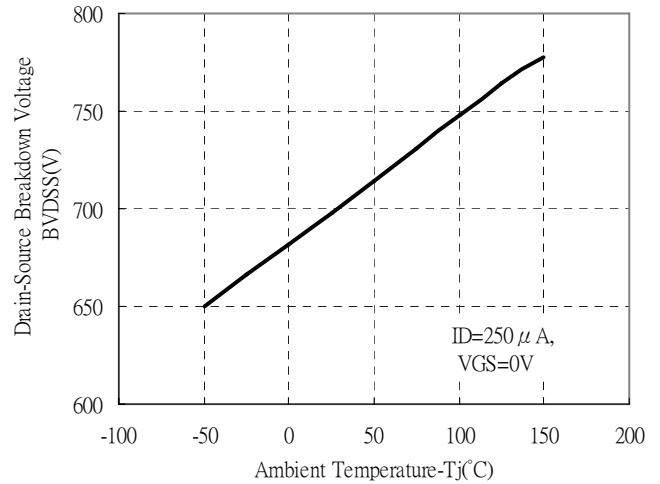

Maximum Safe Operating Area

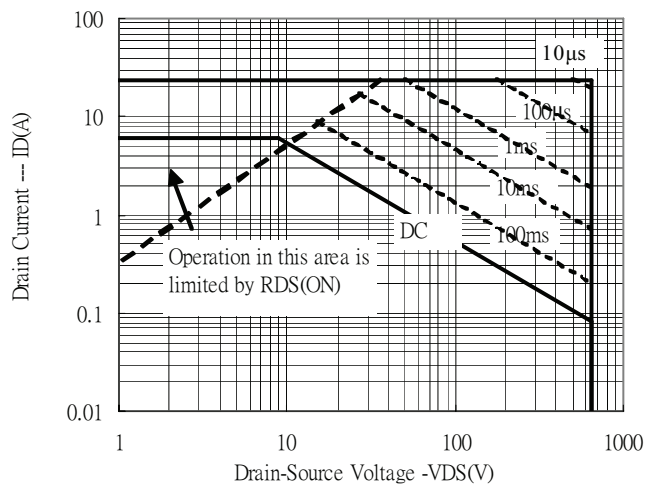

Gate Charge Characteristics

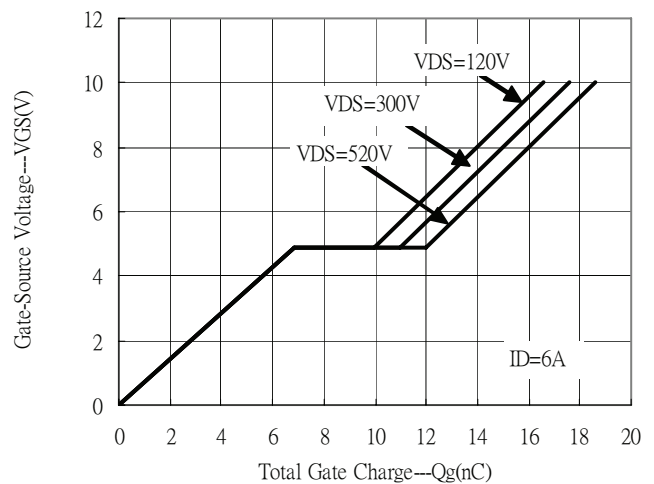

Maximum Drain Current vs Case Temperature

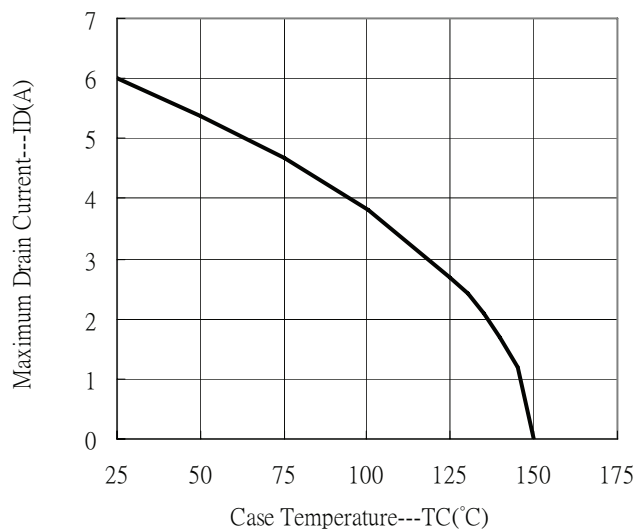

## Typical Characteristics(Cont.)

Transient Thermal Response Curves

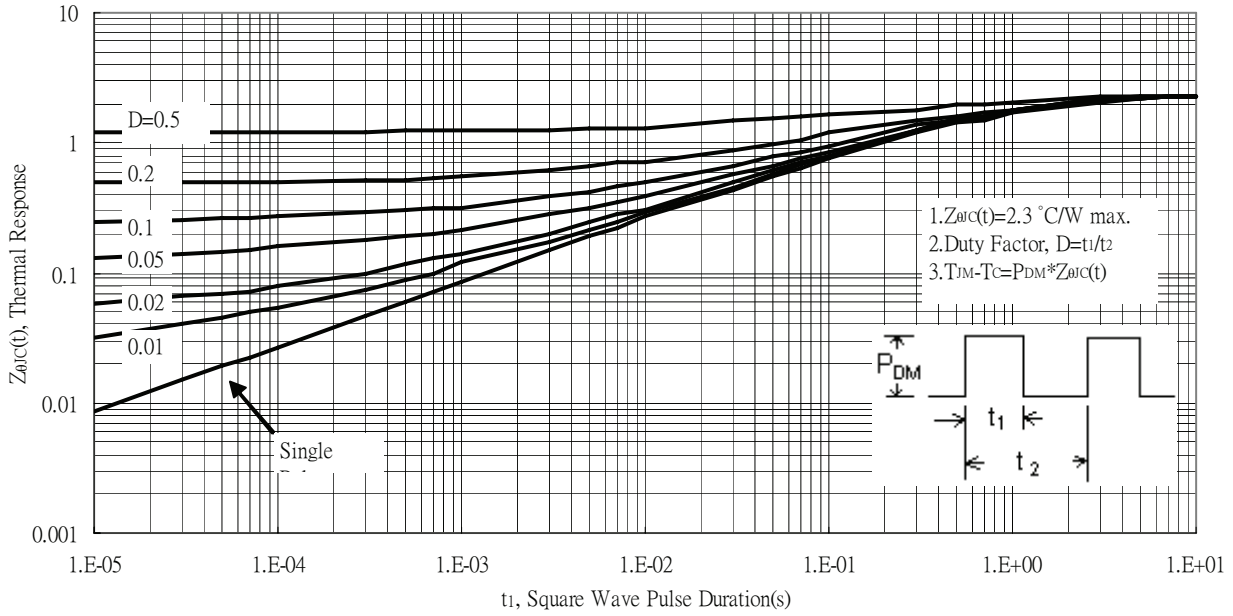

## Test Circuit and Waveforms

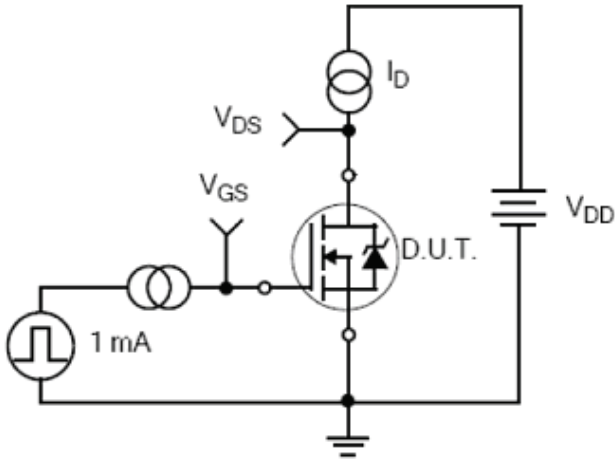

Gate Charge Test Circuit

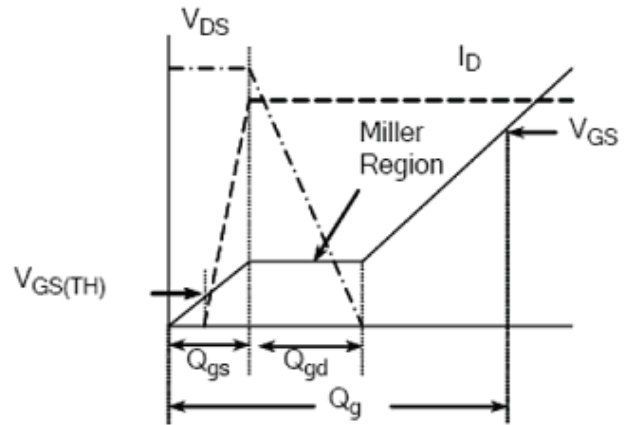

Gate Charge Waveform

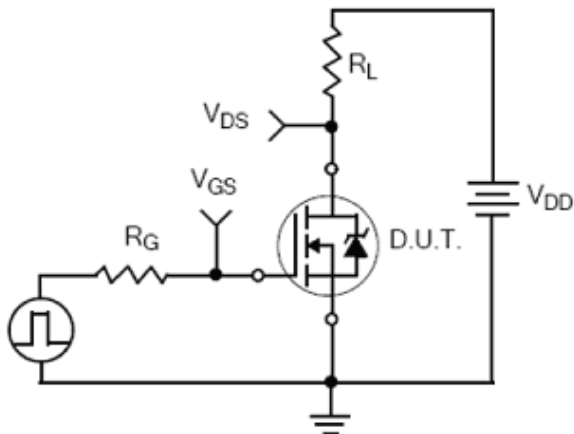

Resistive Switching Test Circuit

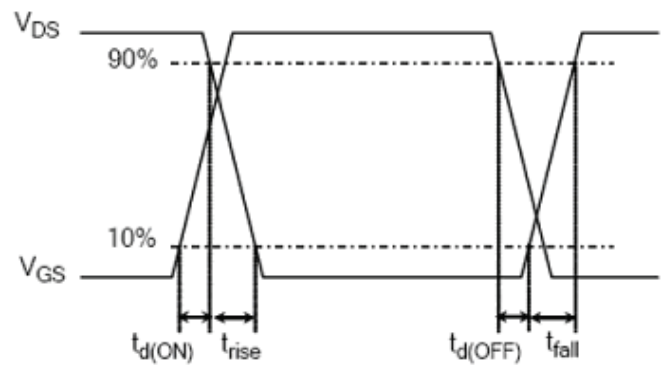

Resistive Switching Waveforms

## Test Circuit and Waveforms(Cont.)

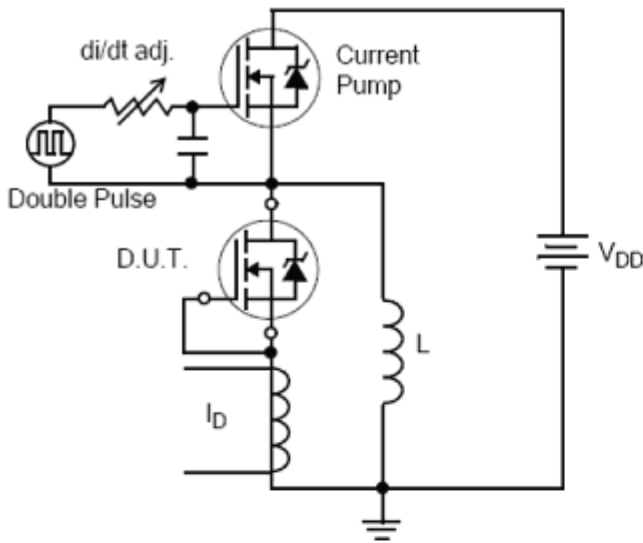

Diode Reverse Recovery Test Circuit

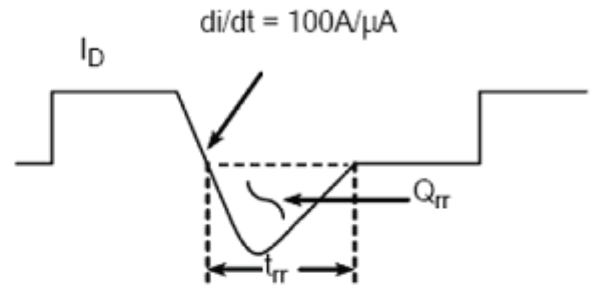

Diode Reverse Recovery Waveform

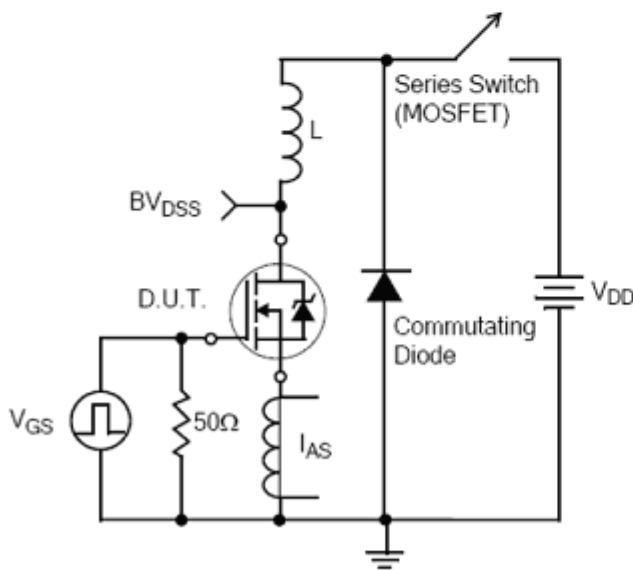

Unclamped Inductive Switching Test Circuit

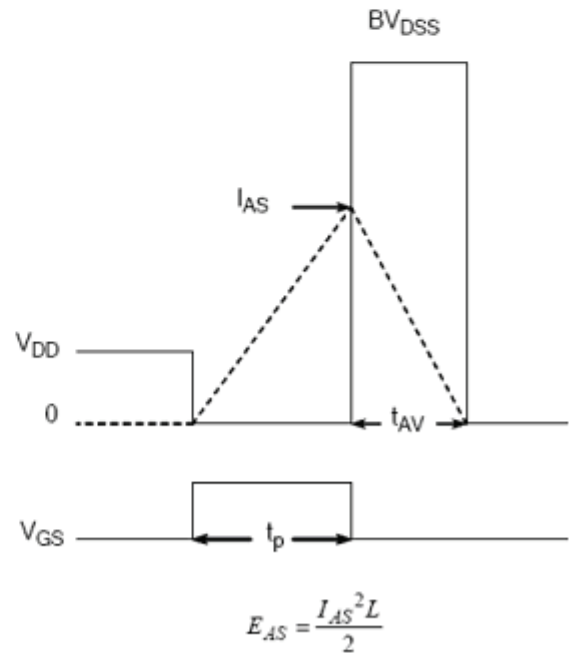

Unclamped Inductive Switching Waveforms



## TO-220 Dimension

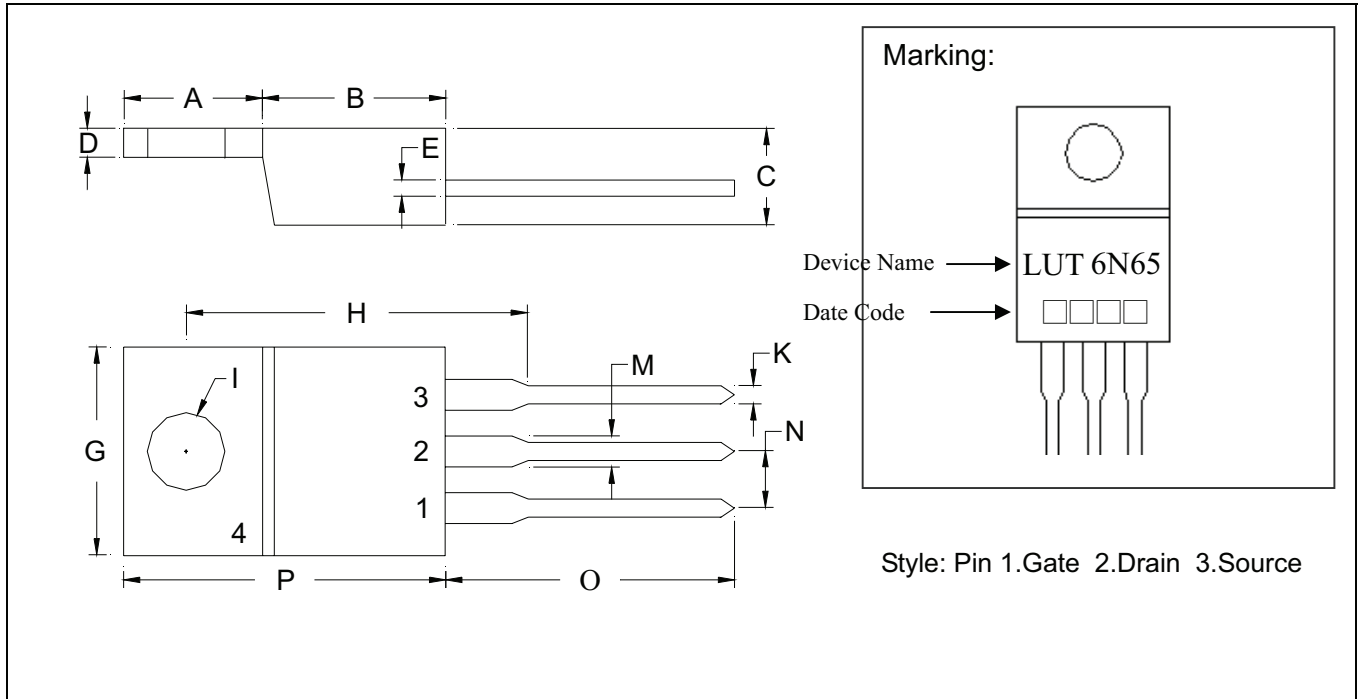

\*

: Typical

DIM	Inches		Millimeters		DIM	Inches		Millimeters	
	Min.	Max.	Min.	Max.		Min.	Max.	Min.	Max.
A	0.2197	0.2949	5.58	7.49	I	-	*0.1508	-	*3.83
B	0.3299	0.3504	8.38	8.90	K	0.0295	0.0374	0.75	0.95
C	0.1732	0.185	4.40	4.70	M	0.0449	0.0551	1.14	1.40
D	0.0453	0.0547	1.15	1.39	N	-	*0.1000	-	*2.54
E	0.0138	0.0236	0.35	0.60	O	0.5000	0.5618	12.70	14.27
G	0.3803	0.4047	9.66	10.28	P	0.5701	0.6248	14.48	15.87
H	-	*0.6398	-	*16.25					

Notes: 1.Controlling dimension: millimeters.  
 2.Maximum lead thickness includes lead finish thickness, and minimum lead thickness is the minimum thickness of base material.  
 3.If there is any question with packing specification or packing method, please contact your local LUL sales office.

**Material:**

- Lead: Pure tin plated.
- Mold Compound: Epoxy resin family, flammability solid burning class: UL94V-0

## TO-220FP (C Forming) Dimension

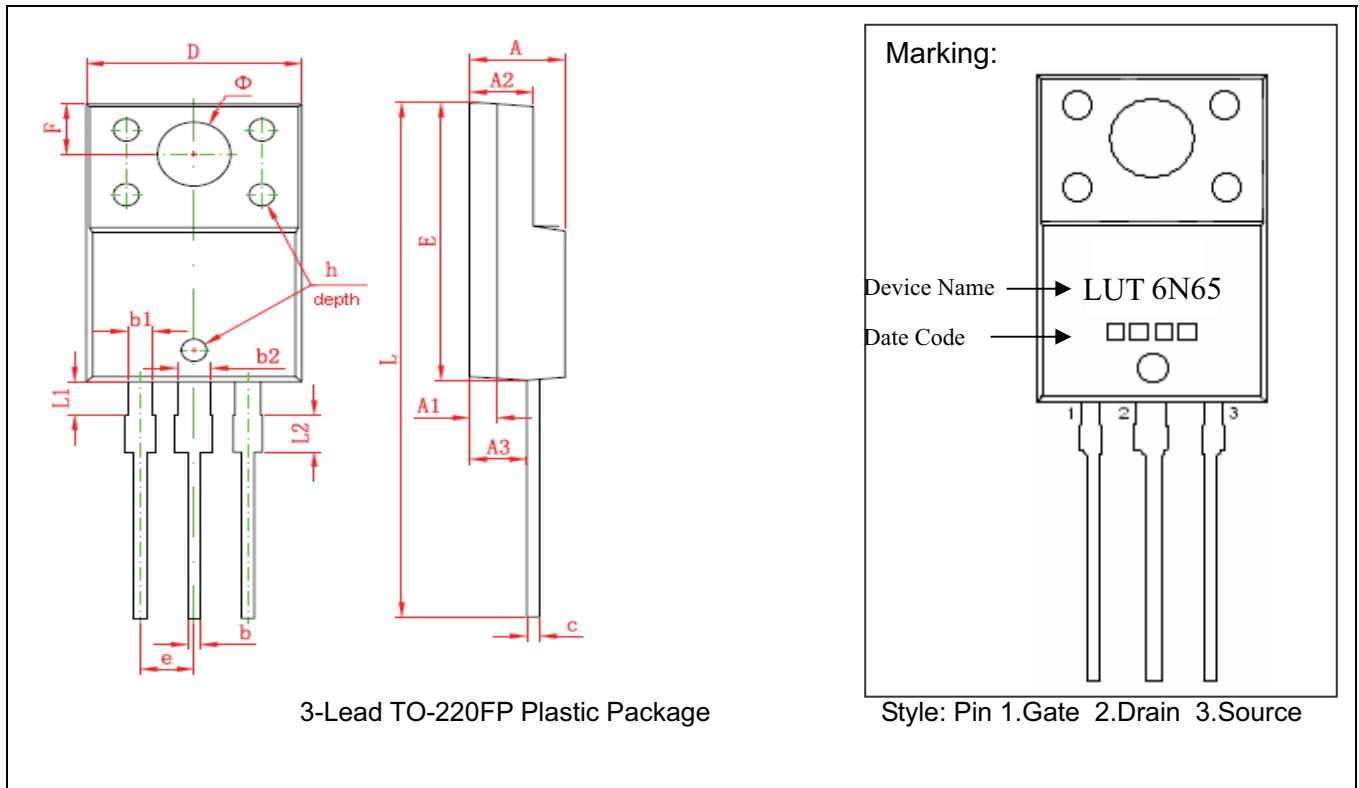

\*Typical

DIM	Inches		Millimeters		DIM	Inches		Millimeters	
	Min.	Max.	Min.	Max.		Min.	Max.	Min.	Max.
A	0.169	0.185	4.300	4.700	E	0.583	0.598	14.800	15.200
A1	0.051 REF		1.300 REF		e	0.100*		2.540*	
A2	0.110	0.126	2.800	3.200	F	0.106 REF		2.700 REF	
A3	0.098	0.114	2.500	2.900	$\Phi$	0.138 REF		3.500 REF	
b	0.020	0.030	0.500	0.750	h	0.000	0.012	0.000	0.300
b1	0.043	0.053	1.100	1.350	L	1.102	1.118	28.000	28.400
b2	0.059	0.069	1.500	1.750	L1	0.067	0.075	1.700	1.900
c	0.020	0.030	0.500	0.750	L2	0.075	0.083	1.900	2.100
D	0.392	0.408	9.960	10.360					

Notes: 1.Controlling dimension: millimeters.

2.Maximum lead thickness includes lead finish thickness, and minimum lead thickness is the minimum thickness of base material.

3.If there is any question with packing specification or packing method, please contact your local LUL sales office.

### Material:

- Lead: Pure tin plated.
- Mold Compound: Epoxy resin family, flammability solid burning class: UL94V-0.

## TO-220FP (S Forming) Dimension

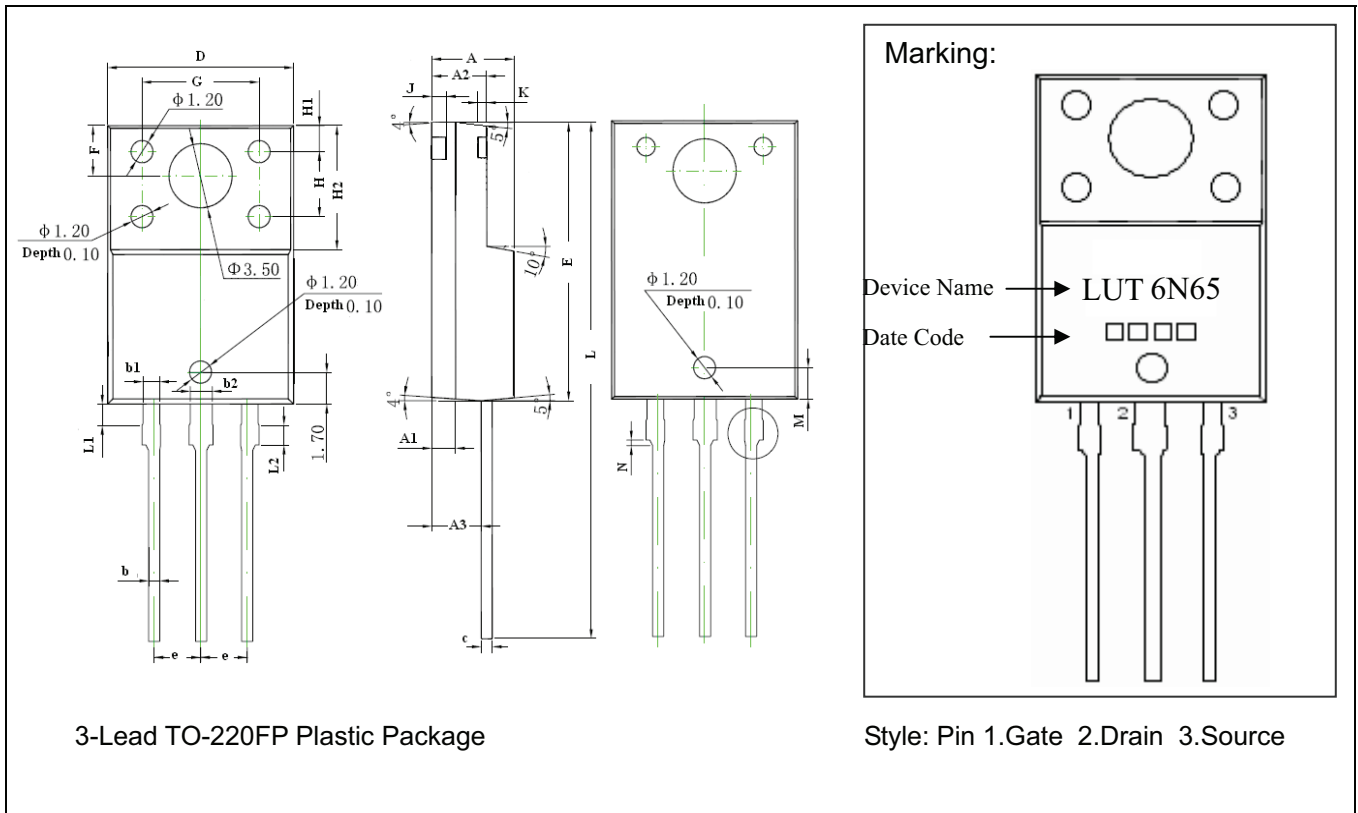

\*Typical

DIM	Inches		Millimeters		DIM	Inches		Millimeters	
	Min.	Max.	Min.	Max.		Min.	Max.	Min.	Max.
A	0.171	0.183	4.35	4.65	G	0.246	0.258	6.25	6.55
A1	0.051 REF		1.300 REF		H	0.138 REF		3.50 REF	
A2	0.112	0.124	2.85	3.15	H1	0.055 REF		1.40 REF	
A3	0.102	0.110	2.60	2.80	H2	0.256	0.272	6.50	6.90
b	0.020	0.030	0.50	0.75	J	0.031 REF		0.80 REF	
b1	0.031	0.041	0.80	1.05	K	0.020		0.50 REF	
b2	0.047 REF		1.20 REF		L	1.102	1.118	28.00	28.40
c	0.020	0.030	0.500	0.750	L1	0.043	0.051	1.10	1.30
D	0.396	0.404	10.06	10.26	L2	0.036	0.043	0.92	1.08
E	0.583	0.598	14.80	15.20	M	0.067 REF		1.70 REF	
e	0.100 *		2.54*		N	0.012 REF		0.30 REF	
F	0.106 REF		2.70 REF						

Notes: 1.Controlling dimension: millimeters.

2.Maximum lead thickness includes lead finish thickness, and minimum lead thickness is the minimum thickness of base material.

3.If there is any question with packing specification or packing method, please contact your local LUL sales office.

Material:

- Lead: Pure tin plated.
- Mold Compound: Epoxy resin family, flammability solid burning class: UL94V-0.

### Important Notice:

- All rights are reserved. Reproduction in whole or in part is prohibited without the prior written approval of LUL.
- LUL reserves the right to make changes to its products without notice.
- LUL **products are not warranted to be suitable for use in Life-Support Applications, or systems.**
- LUL assumes no liability for any consequence of customer product design, infringement of patents, or application assistance.