

P-Channel Logic Level Enhancement Mode Power MOSFET

LUD17P06

BV_{DSS}	-60V
I_D	-17A
$R_{DSON(MAX)}$	62m Ω

Features

- Low Gate Charge
- Simple Drive Requirement
- Pb-free lead plating & Halogen-free package

Equivalent Circuit

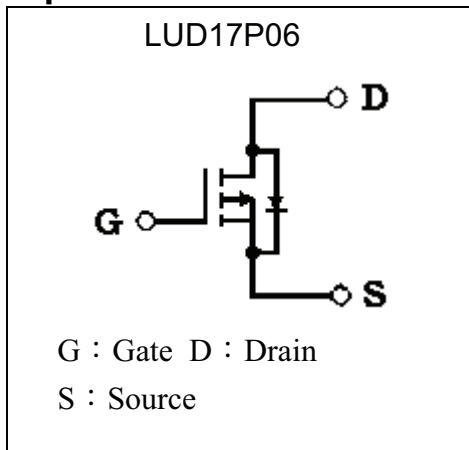

Outline

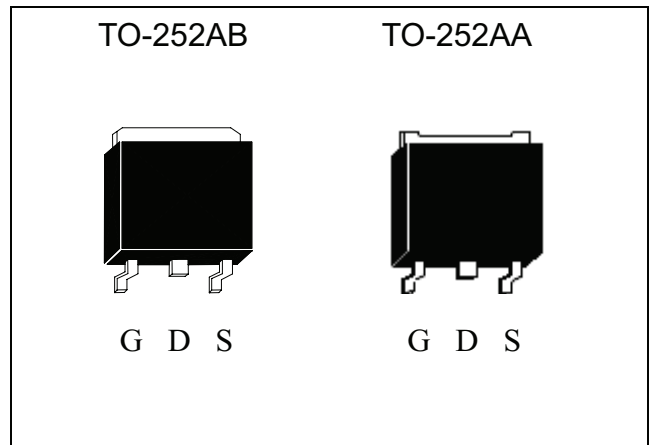

Absolute Maximum Ratings (T_c=25°C, unless otherwise noted)

Parameter	Symbol	Limits	Unit
Drain-Source Voltage	V_{DS}	-60	V
Gate-Source Voltage	V_{GS}	±20	
Continuous Drain Current @ T _c =25°C	I_D	-17	A
Continuous Drain Current @ T _c =100°C	I_D	-11	
Pulsed Drain Current *1	I_{DM}	-60	
Avalanche Current	I_{AS}	-12	
Avalanche Energy @ L=0.1mH, I _D =-12A, R _G =25 Ω	E_{AS}	7.2	mJ
Repetitive Avalanche Energy @ L=0.05mH *2	E_{AR}	3.6	
Total Power Dissipation @T _c =25°C	P_d	33	W
Total Power Dissipation @T _c =100°C		10	
Operating Junction and Storage Temperature Range	T _j , T _{stg}	-55~+175	°C

Note : *1. Pulse width limited by maximum junction temperature

*2. Duty cycle ≤ 1%

Thermal Data

Parameter	Symbol	Value	Unit
Thermal Resistance, Junction-to-case, max	$R_{th,j-c}$	4.5	°C/W
Thermal Resistance, Junction-to-ambient, max	$R_{th,j-a}$	110	°C/W

Characteristics (Tc=25°C, unless otherwise specified)

Symbol	Min.	Typ.	Max.	Unit	Test Conditions
Static					
BV_{DSS}	-60	-	-	V	$V_{GS}=0, I_D=-250\mu A$
$V_{GS(th)}$	-1	-1.8	-3	V	$V_{DS}=V_{GS}, I_D=-250\mu A$
I_{GSS}	-	-	± 100	nA	$V_{GS}=\pm 20, V_{DS}=0$
I_{DSS}	-	-	-1	μA	$V_{DS}=-48V, V_{GS}=0$
	-	-	-25	μA	$V_{DS}=-40V, V_{GS}=0, T_J=125^\circ C$
$I_{D(ON)} *1$	-17	-	-	A	$V_{DS}=-5V, V_{GS}=-4.5V$
$R_{DS(ON)} *1$	-	55	62	m Ω	$V_{GS}=-10V, I_D=-15A$
	-	75	90	m Ω	$V_{GS}=-4.5V, I_D=-7A$
$G_{FS} *1$	-	12	-	S	$V_{DS}=-5V, I_D=-15A$
Dynamic					
$Q_g *1, 2$	-	35	-	nC	$I_D=-10A, V_{DS}=-30V, V_{GS}=-10V$
$Q_{gs} *1, 2$	-	5	-		
$Q_{gd} *1, 2$	-	12	-		
$t_{d(ON)} *1, 2$	-	12	-	ns	$V_{DS}=-10V, I_D=-1A, V_{GS}=-10V, R_G=6\Omega$
$t_r *1, 2$	-	24	-		
$t_{d(OFF)} *1, 2$	-	45	-		
$t_f *1, 2$	-	60	-		
C_{iss}	-	1450	-	pF	$V_{GS}=0V, V_{DS}=-25V, f=1MHz$
C_{oss}	-	160	-		
C_{rss}	-	120	-		
R_g	-	7	-	Ω	$V_{GS}=15mV, V_{DS}=0, f=1MHz$
Source-Drain Diode Ratings and Characteristics					
$I_S *1$	-	-	-17	A	
$I_{SM} *3$	-	-	-60		
$V_{SD} *1$	-	-	-1.3	V	$I_F=I_S, V_{GS}=0V$
t_{rr}	-	12	-	ns	$I_F=-5A, dI_F/dt=100A/\mu s$
Q_{rr}	-	9	-	nC	

Note : *1.Pulse Test : Pulse Width $\leq 300\mu s$, Duty Cycle $\leq 2\%$

*2.Independent of operating temperature

*3.Pulse width limited by maximum junction temperature.

Ordering Information

Device	Package	Shipping
LUD17P06	TO-252 (Pb-free lead plating & Halogen-free package)	2500 pcs / Tape & Reel

Typical Characteristics

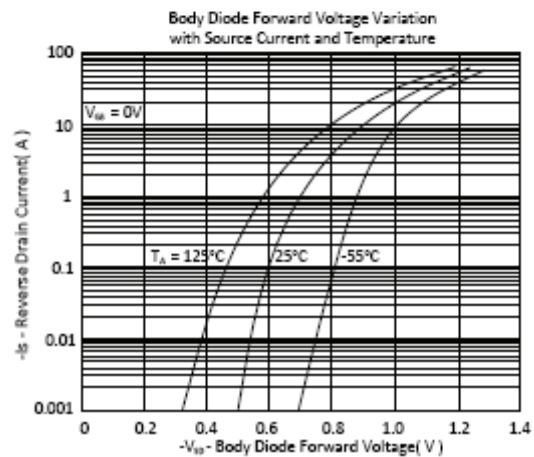
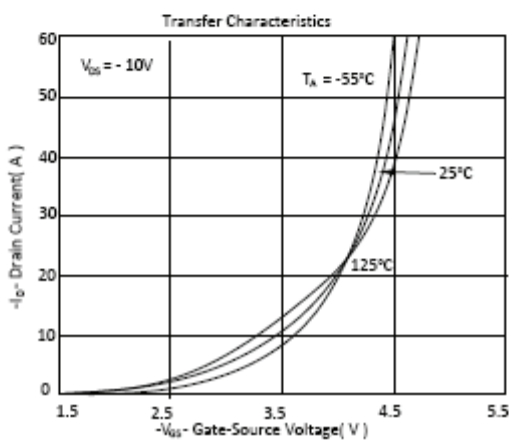
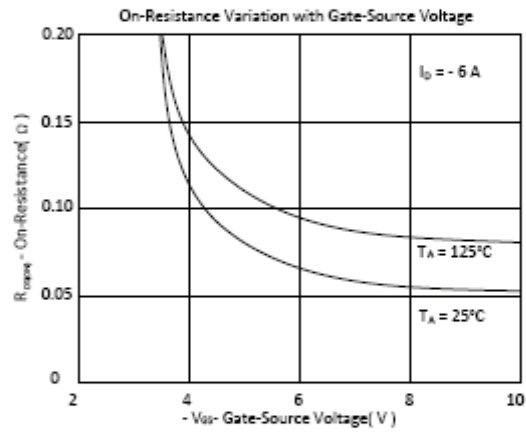
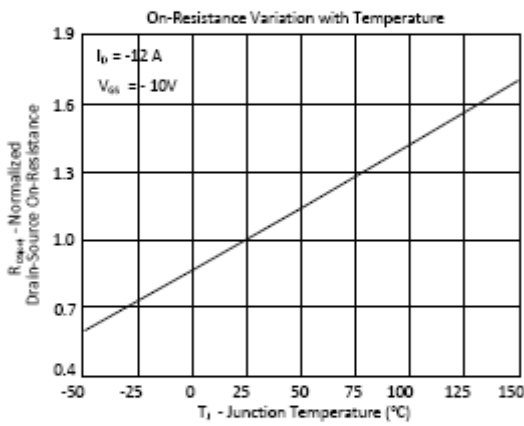
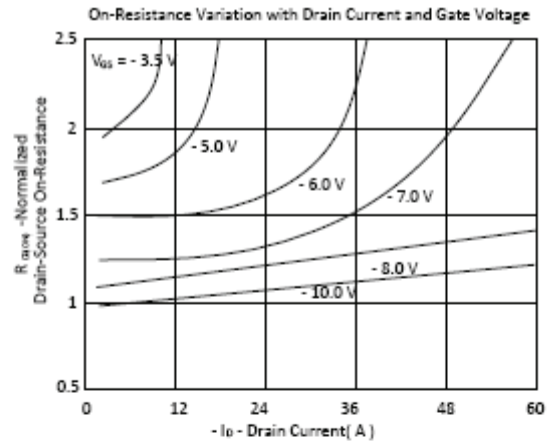
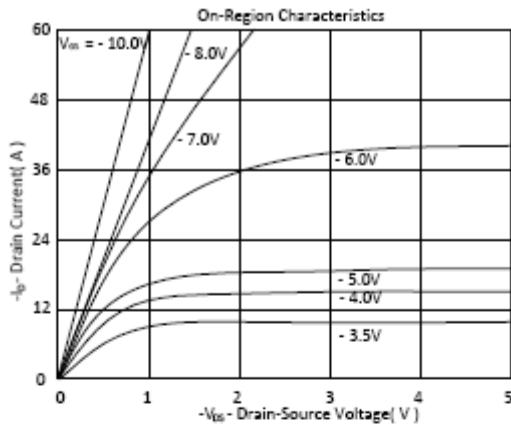

Typical Characteristics (Cont.)

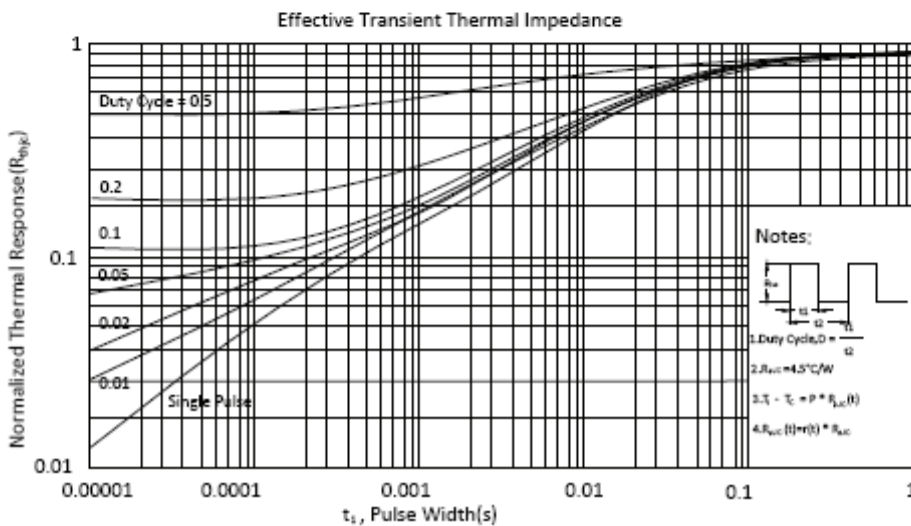
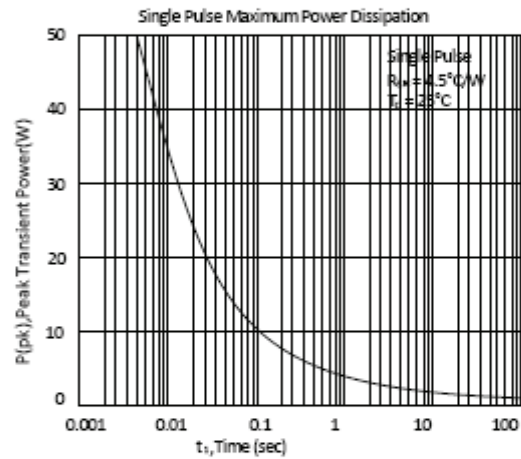
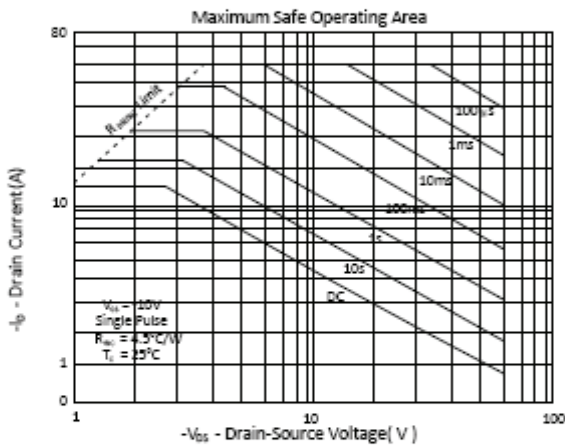
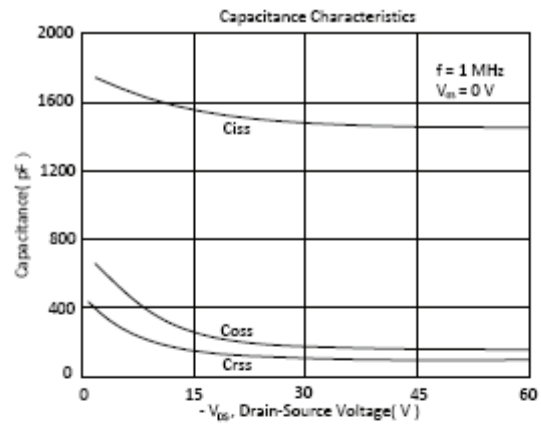
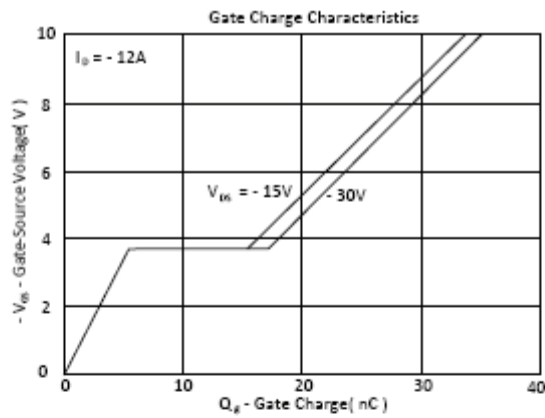

Reel Dimension

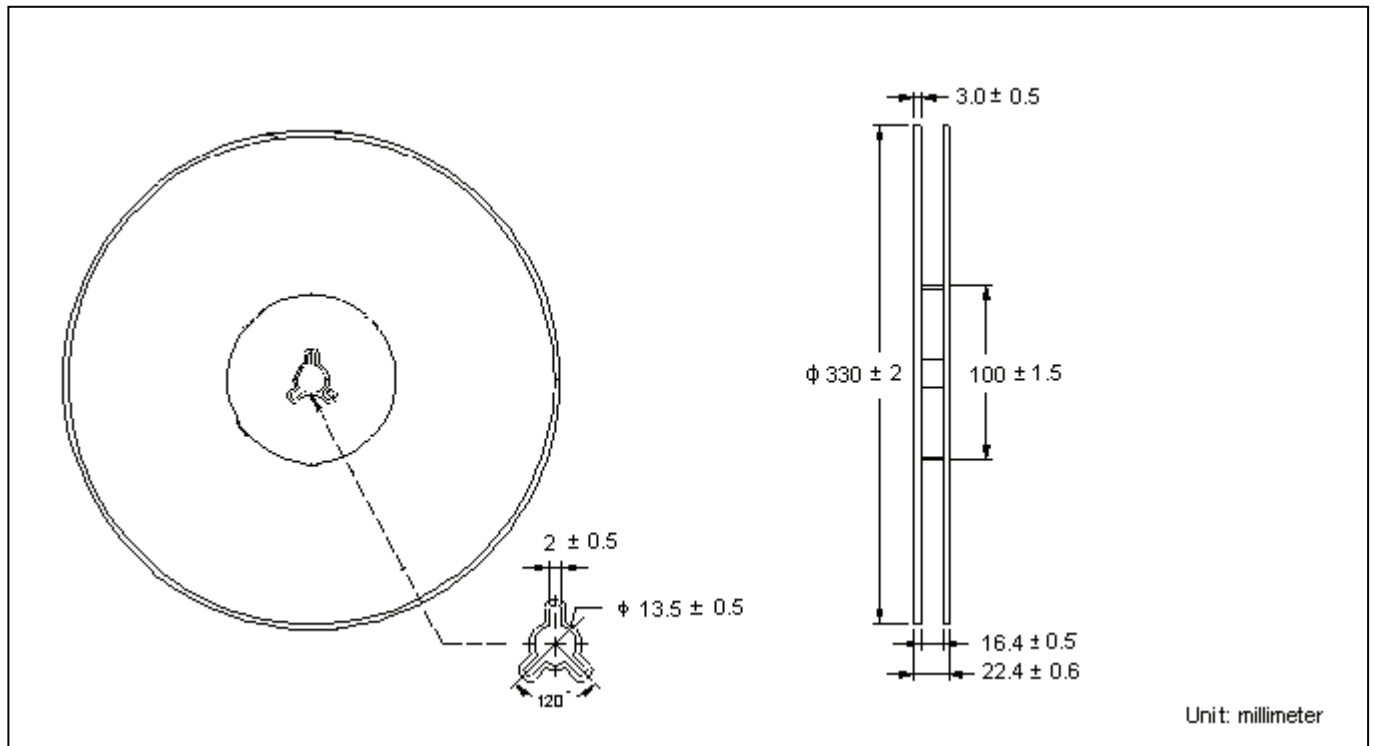

Carrier Tape Dimension

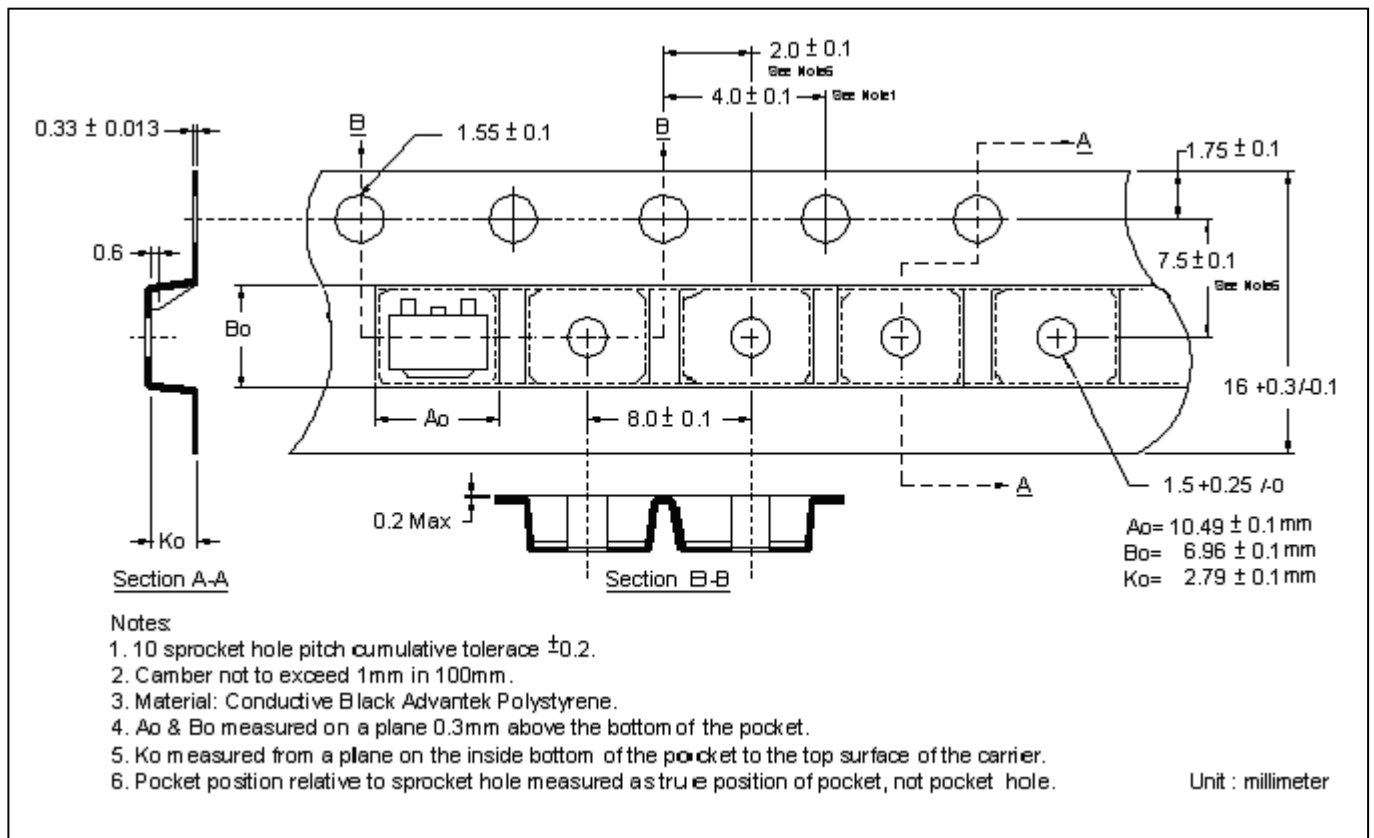

Recommended wave soldering condition

Product	Peak Temperature	Soldering Time
Pb-free devices	260 +0/-5 °C	5 +1/-1 seconds

Recommended temperature profile for IR reflow

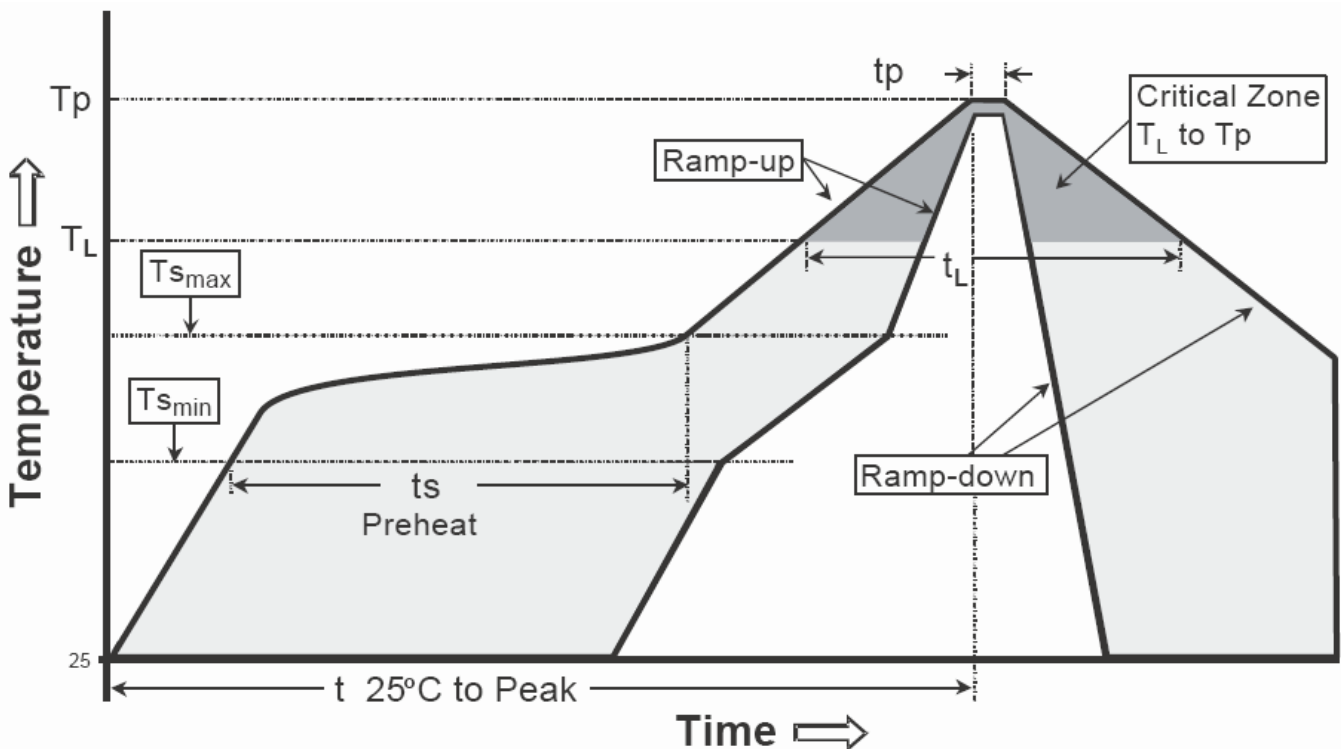

Profile feature	Sn-Pb eutectic Assembly	Pb-free Assembly
Average ramp-up rate (Tsmax to Tp)	3°C/second max.	3°C/second max.
Preheat		
-Temperature Min(Ts min)	100°C	150°C
-Temperature Max(Ts max)	150°C	200°C
-Time(ts min to ts max)	60-120 seconds	60-180 seconds
Time maintained above:		
-Temperature (TL)	183°C	217°C
- Time (tL)	60-150 seconds	60-150 seconds
Peak Temperature(TP)	240 +0/-5 °C	260 +0/-5 °C
Time within 5°C of actual peak temperature(tp)	10-30 seconds	20-40 seconds
Ramp down rate	6°C/second max.	6°C/second max.
Time 25 °C to peak temperature	6 minutes max.	8 minutes max.

Note : All temperatures refer to topside of the package, measured on the package body surface.

TO-252AB Dimension

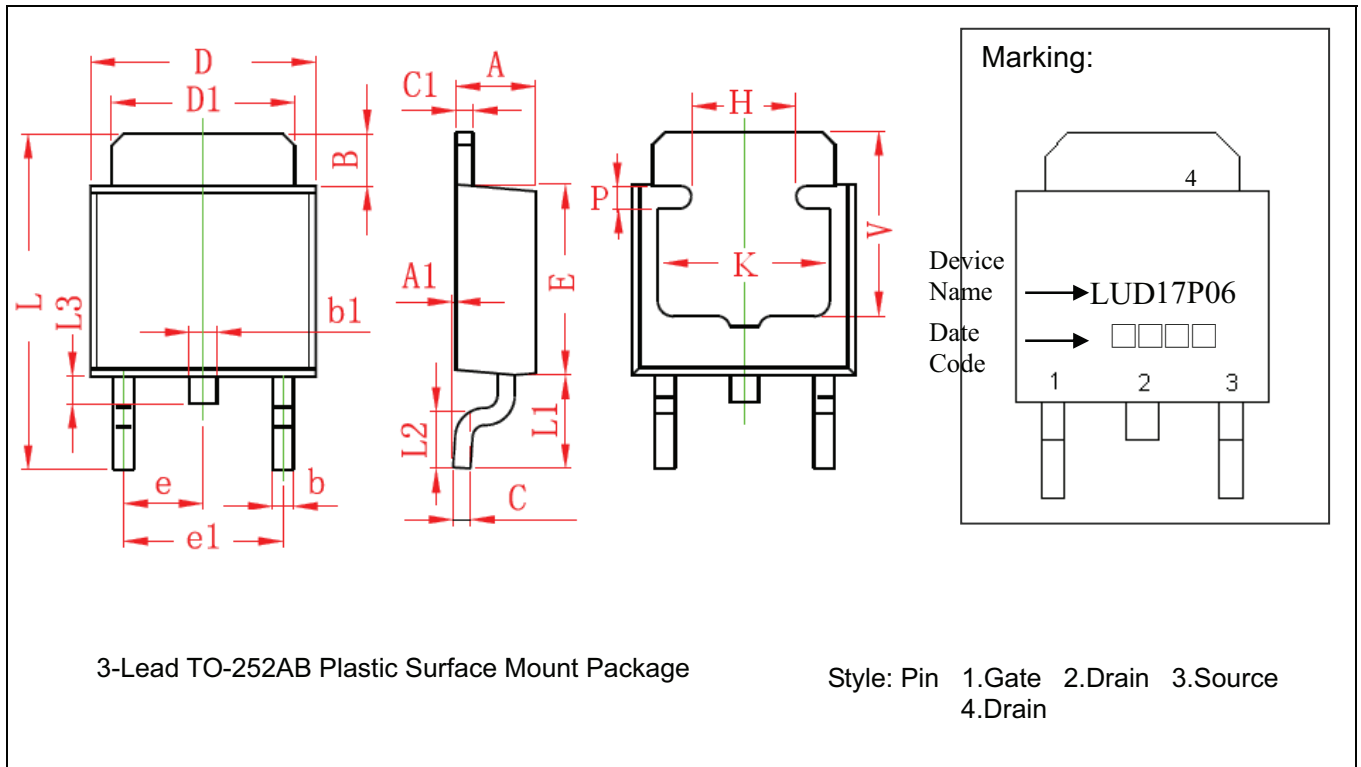

*: Typical

DIM	Inches		Millimeters		DIM	Inches		Millimeters	
	Min.	Max.	Min.	Max.		Min.	Max.	Min.	Max.
A	0.087	0.094	2.200	2.400	e	*0.091		*2.300	
A1	0.000	0.005	0.000	0.127	e1	0.177	0.185	4.500	4.700
B	0.053	0.065	1.350	1.650	H	0.118	REF	3.000	REF
b	0.020	0.028	0.500	0.700	K	0.197	REF	5.000	REF
b1	0.028	0.035	0.700	0.900	L	0.374	0.390	9.500	9.900
C	0.017	0.023	0.430	0.580	L1	0.100	0.114	2.550	2.900
C1	0.017	0.023	0.430	0.580	L2	0.055	0.070	1.400	1.780
D	0.250	0.262	6.350	6.650	L3	0.024	0.035	0.600	0.900
D1	0.205	0.213	5.200	5.400	P	0.028	REF	0.700	REF
E	0.213	0.224	5.400	5.700	V	0.209	REF	5.300	REF

Notes: 1.Controlling dimension: millimeters.
 2.Maximum lead thickness includes lead finish thickness, and minimum lead thickness is the minimum thickness of base material.
 3.If there is any question with packing specification or packing method, please contact your local LUL sales office.

Material:

- Lead : Pure tin plated.
- Mold Compound: Epoxy resin family, flammability solid burning class: UL94V-0.

TO-252AA Dimension

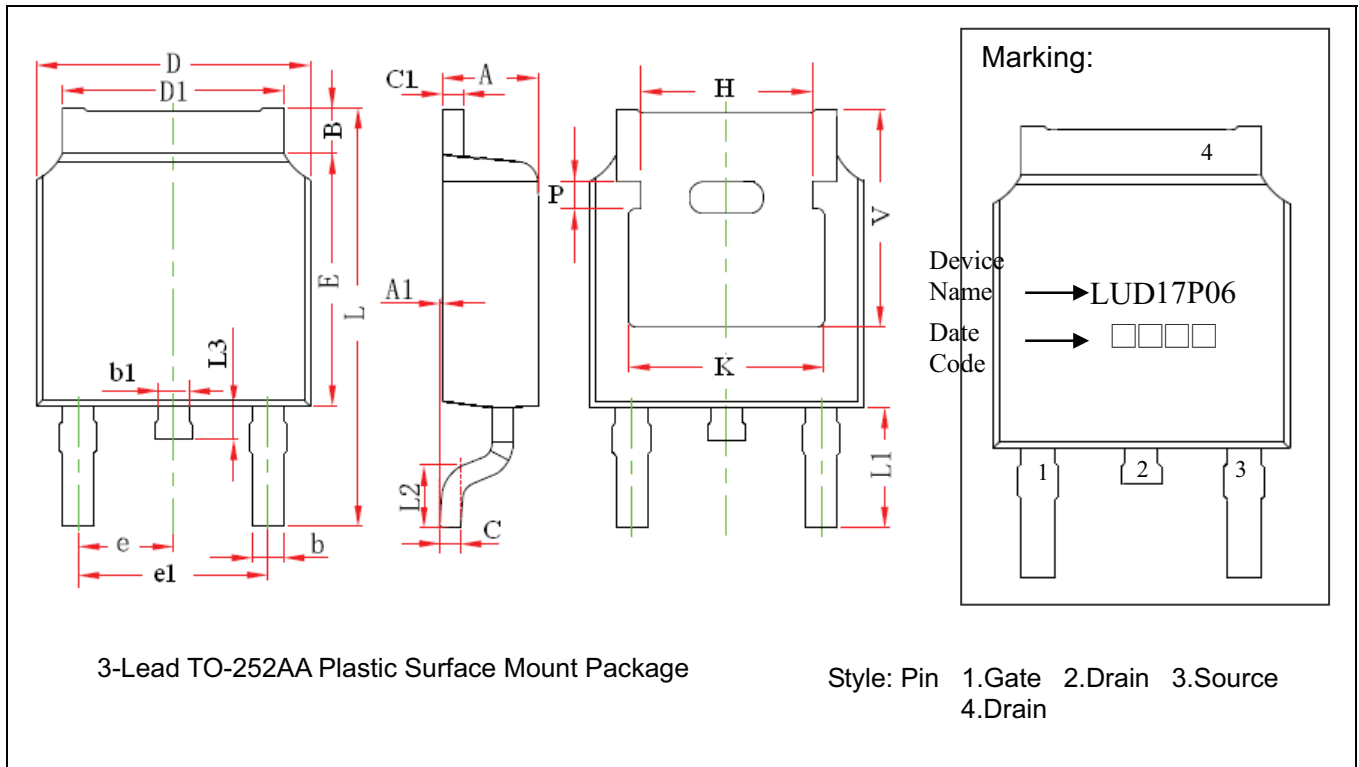

DIM	Inches		Millimeters		DIM	Inches		Millimeters	
	Min.	Max.	Min.	Max.		Min.	Max.	Min.	Max.
A	0.087	0.094	2.200	2.400	e	0.086	0.094	2.186	2.386
A1	0.000	0.005	0.000	0.127	e1	0.172	0.188	4.372	4.772
B	0.039	0.048	0.990	1.210	H	0.163	REF	4.140	REF
b	0.026	0.034	0.660	0.860	K	0.190	REF	4.830	REF
b1	0.026	0.034	0.660	0.860	L	0.386	0.409	9.800	10.400
C	0.018	0.023	0.460	0.580	L1	0.114	REF	2.900	REF
C1	0.018	0.023	0.460	0.580	L2	0.055	0.067	1.400	1.700
D	0.256	0.264	6.500	6.700	L3	0.024	0.039	0.600	1.000
D1	0.201	0.215	5.100	5.460	P	0.026	REF	0.650	REF
E	0.236	0.244	6.000	6.200	V	0.211	REF	5.350	REF

Notes: 1.Controlling dimension: millimeters.

2.Maximum lead thickness includes lead finish thickness, and minimum lead thickness is the minimum thickness of base material.

3.If there is any question with packing specification or packing method, please contact your local LUL sales office.

Material:

- Lead : Pure tin plated.
- Mold Compound: Epoxy resin family, flammability solid burning class: UL94V-0.

Important Notice:

- All rights are reserved. Reproduction in whole or in part is prohibited without the prior written approval of LUL.
- LUL reserves the right to make changes to its products without notice.
- LUL **products are not warranted to be suitable for use in Life-Support Applications, or systems.**
- LUL assumes no liability for any consequence of customer product design, infringement of patents, or application assistance.