

**Three Terminal Adjustable Output
 Positive Voltage Regulators**

LM317E3

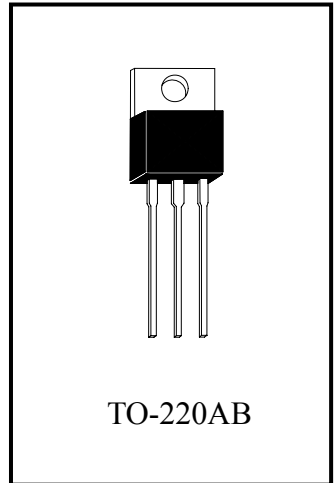

The LM317E3 is an adjustable 3-terminal positive voltage regulator capable of supplying in excess of 1.5 A over an output voltage range of 1.2 V to 37 V. This voltage regulator is exceptionally easy to use and requires only two external resistors to set the output voltage. Further, it employs internal current limiting, thermal shutdown and safe area compensation, making it essentially blow-out proof.

The LM317E3 serves a wide variety of applications including local, on-card regulation. This device can also be used to make a programmable output regulator, or by connecting a fixed resistor between the adjustment and output, the LM317E3 can be used as a precision current regulator.

- Output Current in Excess of 1.5 A
- Output Adjustable between 1.2 V and 37 V
- Internal Thermal Overload Protection
- Internal Short Circuit Current Limiting Constant with Temperature
- Output Transistor Safe-Area Compensation
- Floating Operation for High Voltage Applications
- Eliminates Stocking many Fixed Voltages

Standard Application

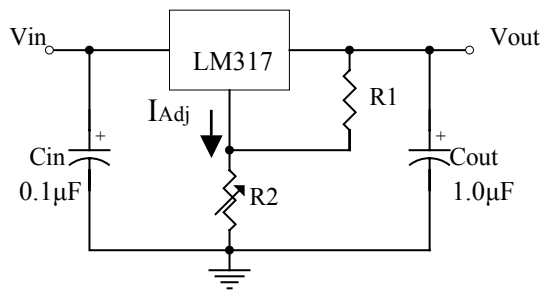

* Cin is required if regulator is located an appreciate distance from power supply filter.

* * Cout is not needed for stability, however, it does improve transient response.

$V_{out} = 1.25(1 + R_2/R_1) + I_{Adj}R_2$

Since I_{Adj} is controlled to less than 100 μA , the error associated with this term is negligible in most applications.

Maximum Ratings

Rating	Symbol	Value	Unit
Input-Output Voltage Differential	$V_I - V_O$	40	V
Power Dissipation $T_A = 25^\circ C$	P_D	Internally Limited	W
Thermal Resistance, Junction-to-Ambient	θ_{JA}	65	$^\circ C/W$
Thermal Resistance, Junction-to-Case	θ_{JC}	5.0	$^\circ C/W$
Operating Junction Temperature Range	T_J	-40 to +125	$^\circ C$
Storage Temperature Range	T_{stg}	-65 to +150	$^\circ C$

**Electrical Characteristics**($V_I-V_O=5V, I_O=0.5A, T_J=0$ to $125^{\circ}C$, unless otherwise noted)

Characteristics	Symbol	Conditions	Min	Typ	Max	Unit
Line Regulation(Notes 1)	Reg _{line}	$T_A=25^{\circ}C, 3.0V \leq V_I-V_O \leq 40V$	-	0.01	0.04	%/V
Load Regulation(Notes 1)	Reg _{load}	$T_A=25^{\circ}C, 10mA \leq I_O \leq 1.5A$	-	5.0	25	mV
		$V_O \leq 5.0V$	-	0.1	0.5	% V_O
		$V_O \geq 5.0V$	-	-	-	-
Thermal Regulation(Notes 4)	Reg _{therm}	$T_A=25^{\circ}C, 20ms$ pulse	-	0.03	0.07	% V_O/W
Adjust Pin Current	I_{Adj}		-	50	100	μA
Adjust Pin Current Change	ΔI_{Adj}	$2.5V \leq V_I-V_O \leq 40V, 10mA \leq I_L \leq 1.5A$ $P_D \leq 20W$	-	0.2	5.0	μA
Reference Voltage	V_{ref}	$3.0V \leq V_I-V_O \leq 40V, 10mA \leq I_O \leq 1.5A$ $P_D \leq 20W$	1.2	1.25	1.3	V
Temperature Stability	T_s	$0 \leq T_J \leq 125^{\circ}C$	-	0.7	-	% V_O
Minimum Load Current to maintain Regulation	I_{Lmin}	$V_I-V_O=40V$	-	3.5	10	mA
Maximum Output Current	I_{max}	$V_I-V_O \leq 15V, P_D \leq 20W$	1.5	2.2	-	A
		$V_I-V_O \leq 40V, P_D \leq 20W, T_A=25^{\circ}C$	0.15	0.4	-	-
RMS Noise	N	% of $V_O, T_A=25^{\circ}C, 10Hz \leq f \leq 10kHz$	-	0.003	-	% V_O
Ripple Rejection(Notes 2)	RR	$V_O=10V, f=120Hz$	-	65	-	dB
		Without C_{Adj} $C_{Adj}=10\mu F$	66	80	-	-
Long-Term Stability(Notes 3)	S	$T_J=125^{\circ}C, T_A=25^{\circ}C$ for endpoint measurements	-	0.3	1.0	%/1.0k Hrs

- Notes: 1. Load and line regulation are specified at constant junction temperature. Changes in V_O due to heating effects must be taken into account separately. Pulse testing with low duty cycle is used.
2. C_{Adj} , when used, is connected between the adjustment pin and ground.
3. Since long-term stability cannot be measured on each device before shipment, this specification is an engineering estimate of average stability from lot to lot.
4. Power dissipation within an IC voltage regulator produces a temperature gradient on the die, affecting individual IC components on the die. These effects can be minimized by proper integrated circuit design and layout techniques. Thermal regulation is the effect of these temperature gradients on the output voltage and is expressed in percentage of output change per watt of power change in a specified time.

Characteristic Curves

Reference Voltage vs Temperature

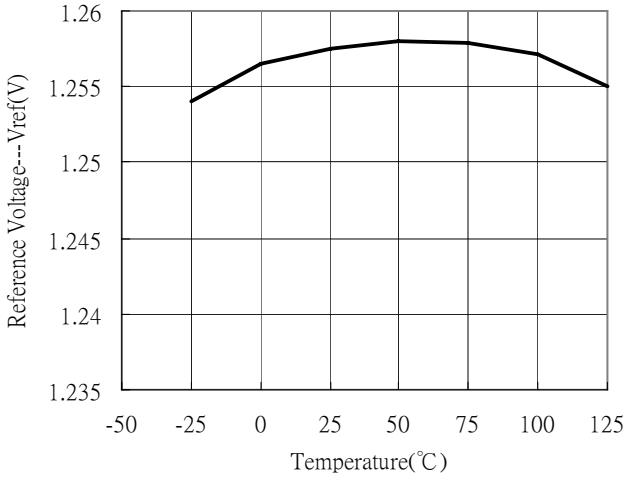

Adjustment Current vs Temperature

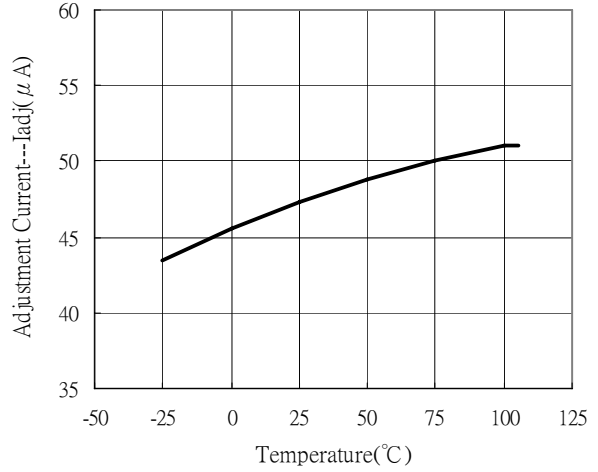

Dropout Voltage vs Input-Output Voltage Difference

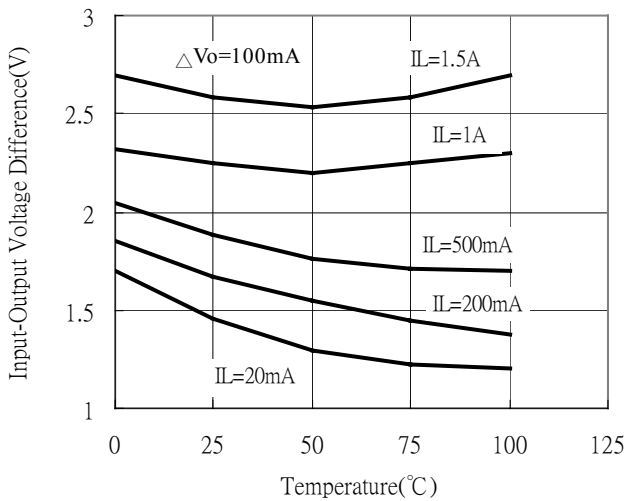

Representative Schematic Diagram

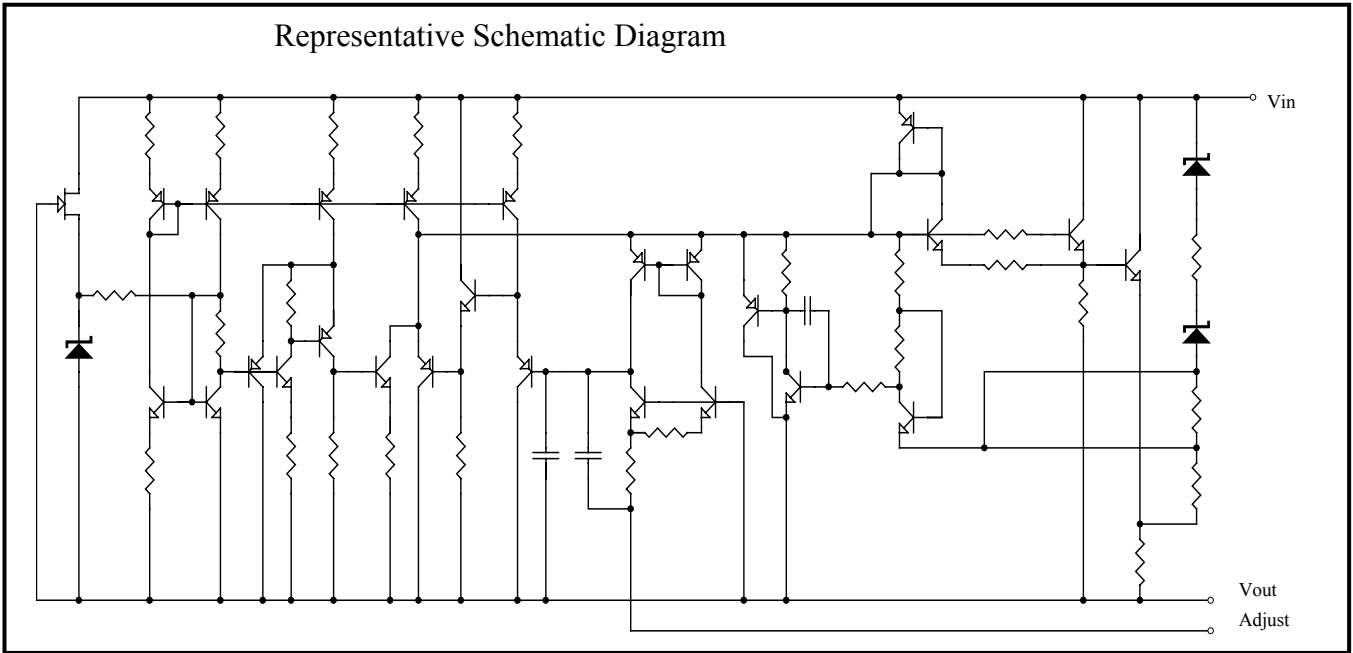

$$\text{Line Regulation}(\%/V) = \frac{|V_{OH} - V_{OL}|}{|V_{OL}|} \times 100$$

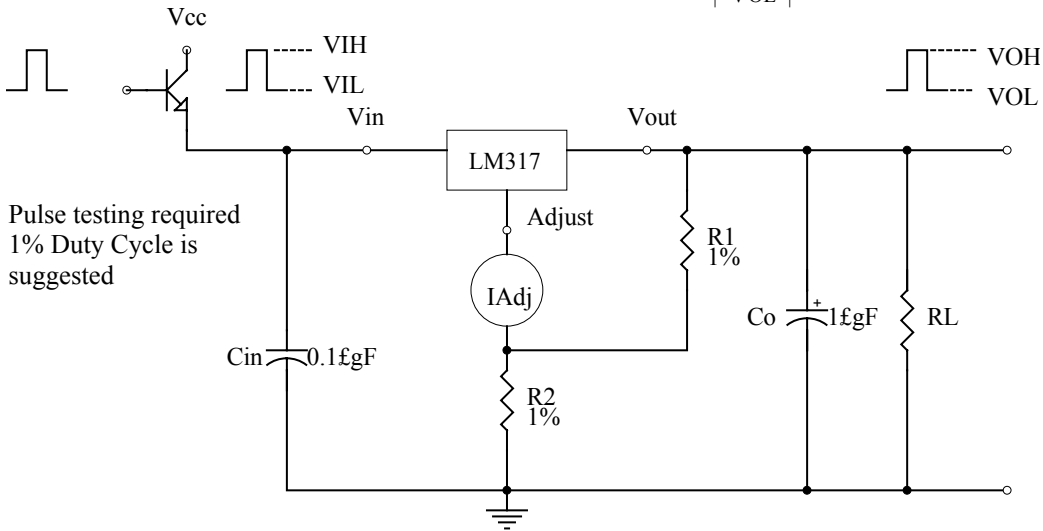

Fig 1. Line Regulation and ΔI_{Adj} /Line test circuit

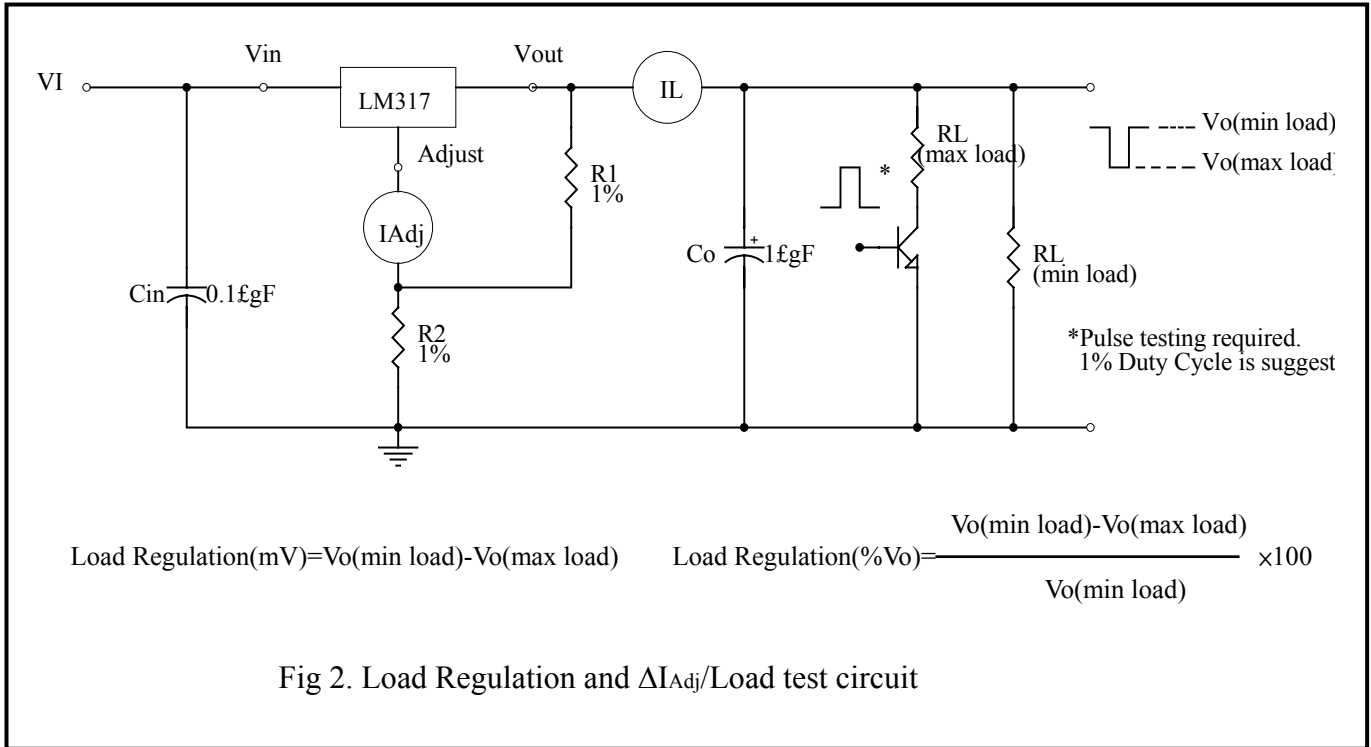

Fig 2. Load Regulation and ΔI_{Adj} /Load test circuit

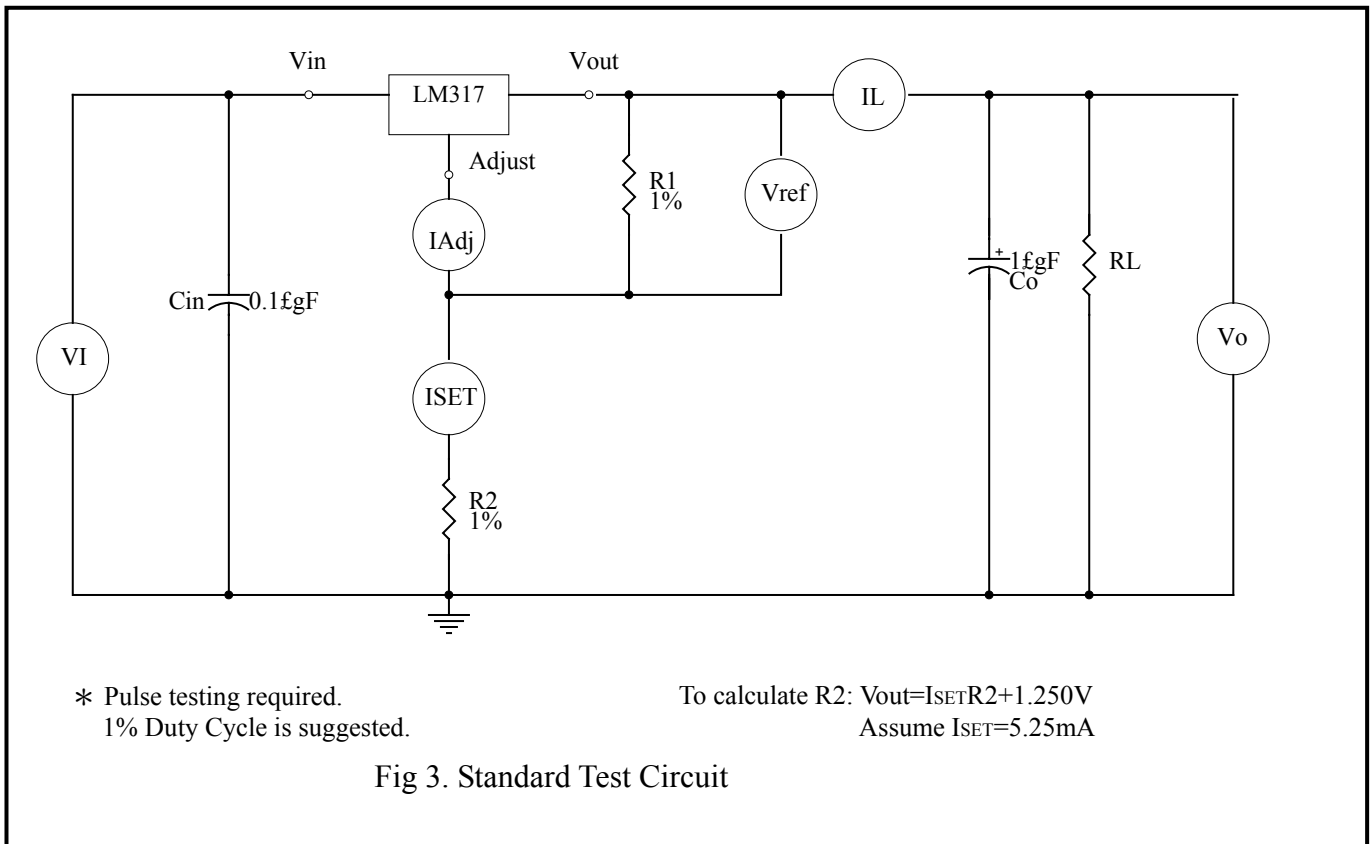

Fig 3. Standard Test Circuit

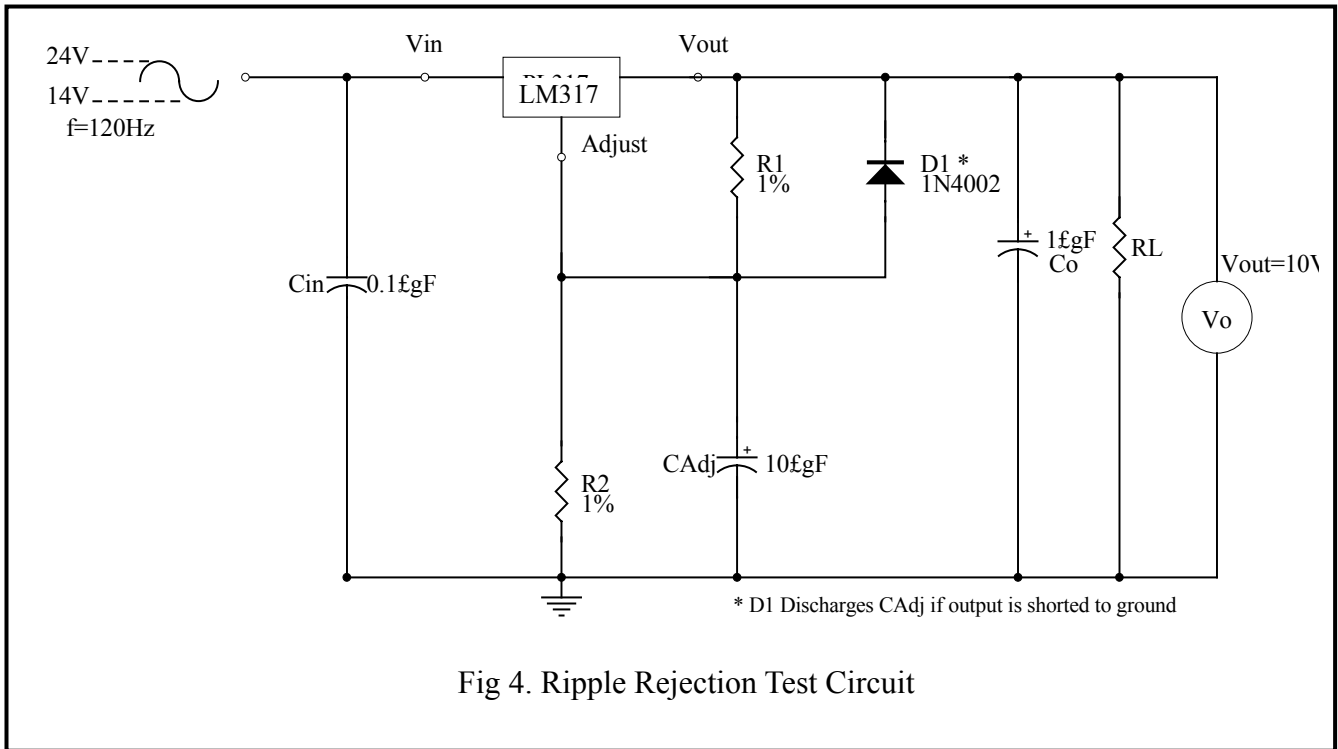

Fig 4. Ripple Rejection Test Circuit

Application Information

Basic Circuit Operation

The LM317 is a 3-terminal floating regulator. In operation, the LM317 develops and maintains a nominal 1.25V reference (V_{ref}) between its output and adjustment terminals. This reference voltage is converted to a programming current (I_{prog}) by R_1 (see Fig 5), and this constant current flows through R_2 to ground. The regulated output voltage is given by:

$$V_{out} = V_{ref} \left(1 + \frac{R_2}{R_1} \right) + I_{Adj} R_2$$

Since the current from the adjustment terminal (I_{Adj}) represents an error term in the equation, the LM317 was designed to control I_{Adj} to less than 100 μA and keep it constant. To do this, all quiescent operating current is returned to the output terminal. This imposes the requirement for a minimum load current. If the load current is less than this minimum, the output voltage will rise.

Since the LM317 is a floating regulator, it is only the voltage differential across the circuit which is important to performance, and operation at high voltages with respect to ground is possible.

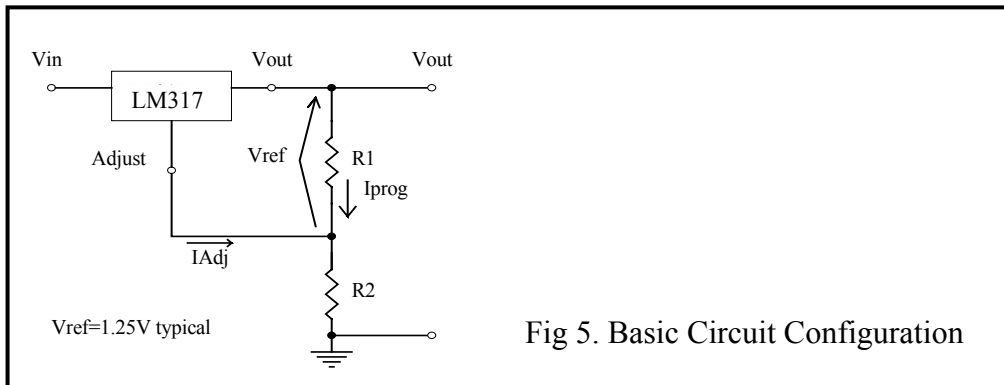

Fig 5. Basic Circuit Configuration

Load Regulation

The LM317 is capable of providing extremely good load regulation, but a few precautions are needed to obtain maximum performance. For best performance, the programming resistor (R1) should be connected as close to the regulator as possible to minimize line drops which effectively appear in series with the reference, thereby degrading regulation. The ground end of R2 can be returned near the load ground to provide remote ground sensing and improve load regulation.

External Capacitors

A 0.1µF disc or 1.0µF tantalum input bypass capacitor (Cin) is recommended to reduce the sensitivity to input line impedance.

The adjustment terminal may be bypassed to ground to improve ripple rejection. This capacitor (CAdj) prevents ripple from being amplified as the output voltage is increased. A 10µF capacitor should improve ripple rejection about 15 dB at 120 Hz in a 10V application.

Although the LM317 is stable with no output capacitance, like any feedback circuit, certain values of external capacitance can cause excessive ringing. An output capacitance (Co) in the form of a 1.0µF tantalum or 25µF aluminum electrolytic capacitor on the output swamps this effect and insures stability.

Protection Diodes

When external capacitors are used with any IC regulator, it is sometimes necessary to add protection diodes to prevent the capacitors from discharging through low current points into the regulator.

Fig 6 shows the LM317 with the recommended protection diodes for output voltages in excess of 25V or high capacitance values (Co>25µF, CAdj>10µF). Diode D1 prevents Co from discharging thru the IC during an input short circuit. Diode D2 protects against capacitor CAdj discharging through the IC during an output short circuit. The combination of diodes D1 and D2 prevents CAdj from discharging through the IC during an input short circuit.

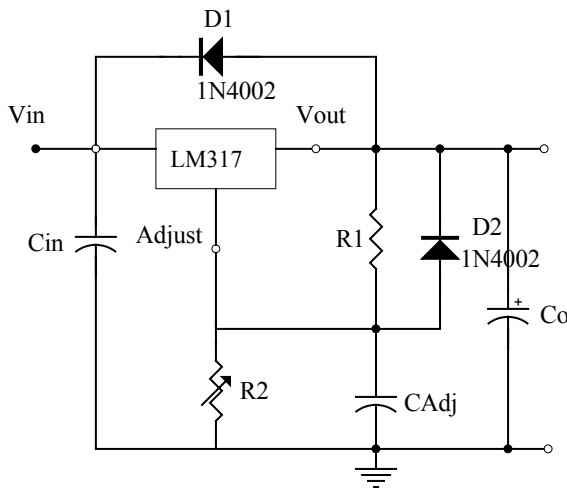
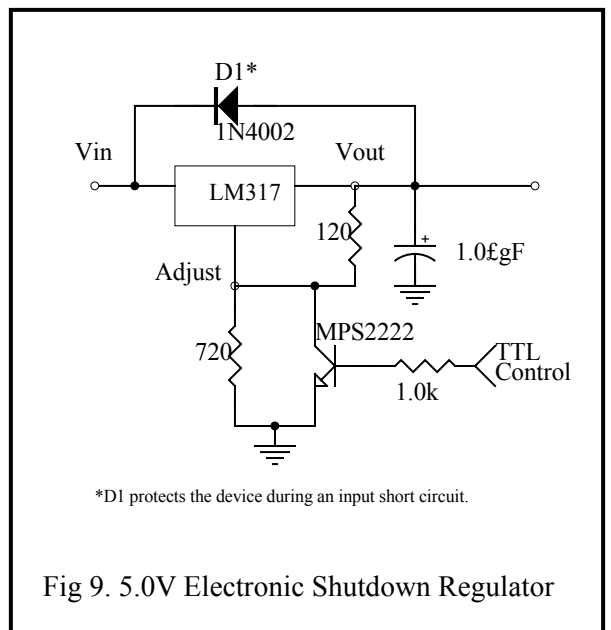
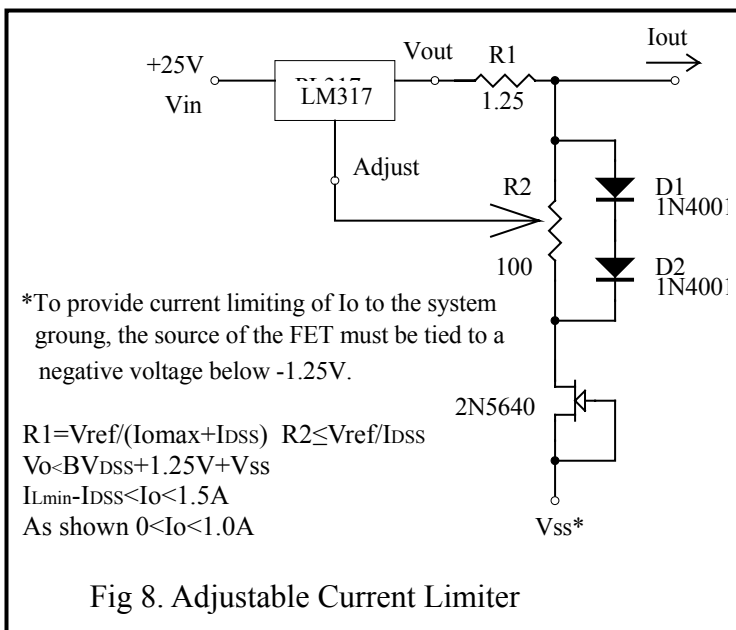
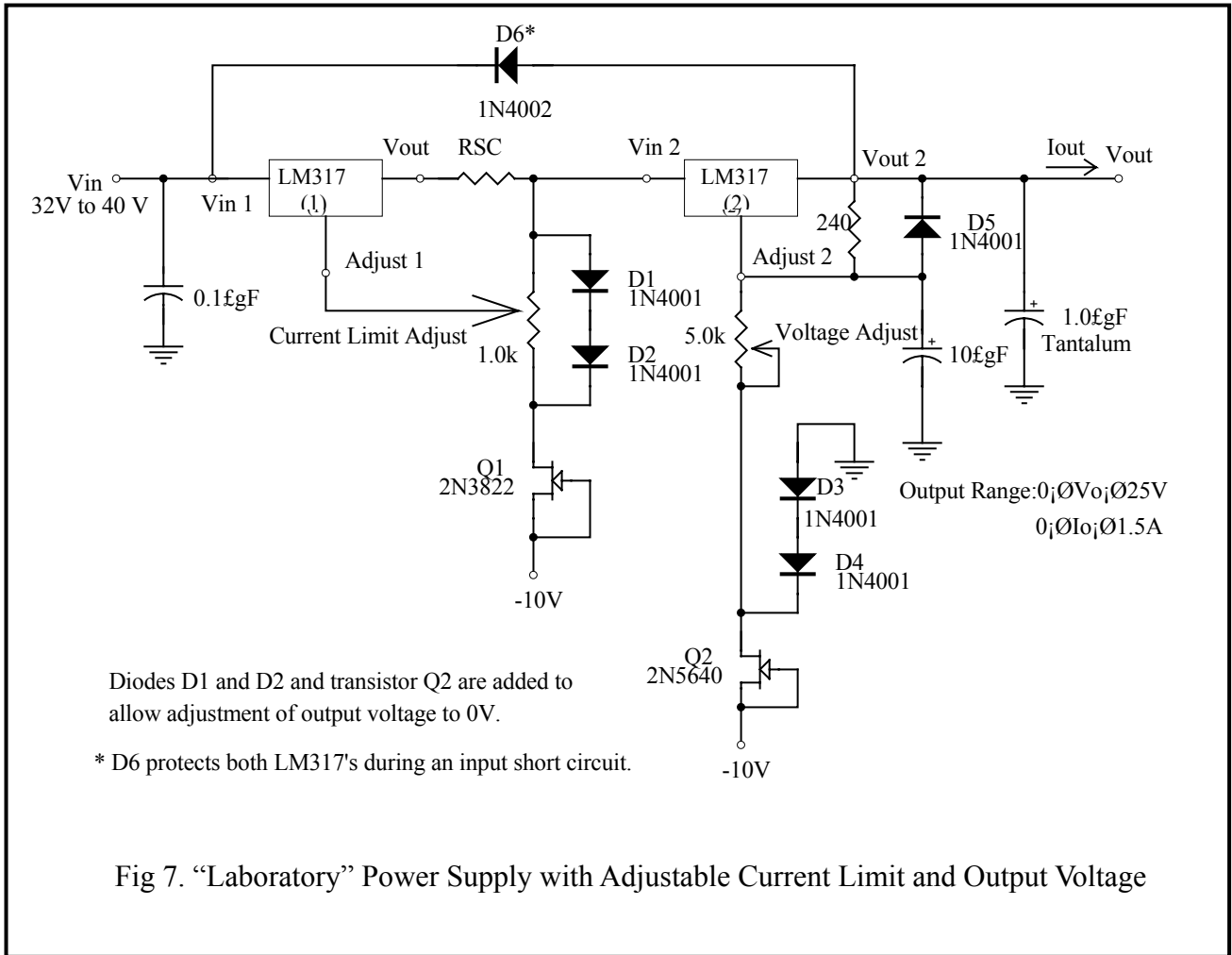
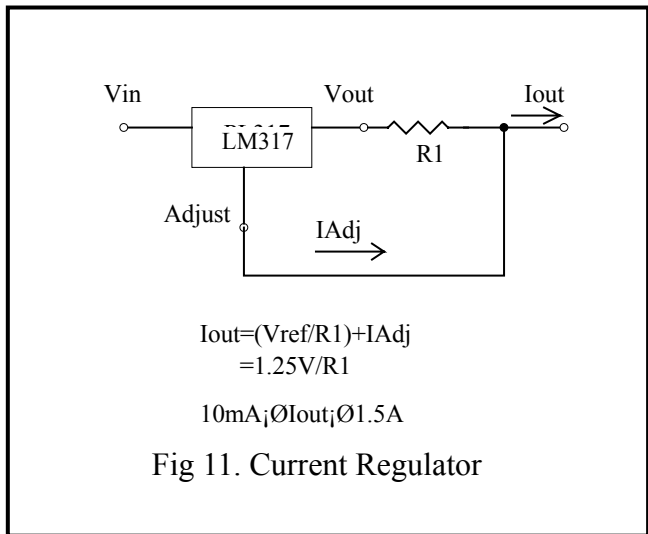
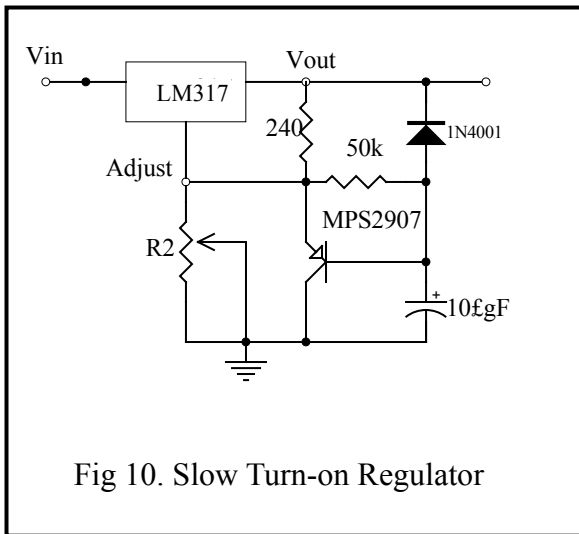

Fig 6. Voltage Regulator with Protection Diodes

Application Circuits





TO-220AB Dimension

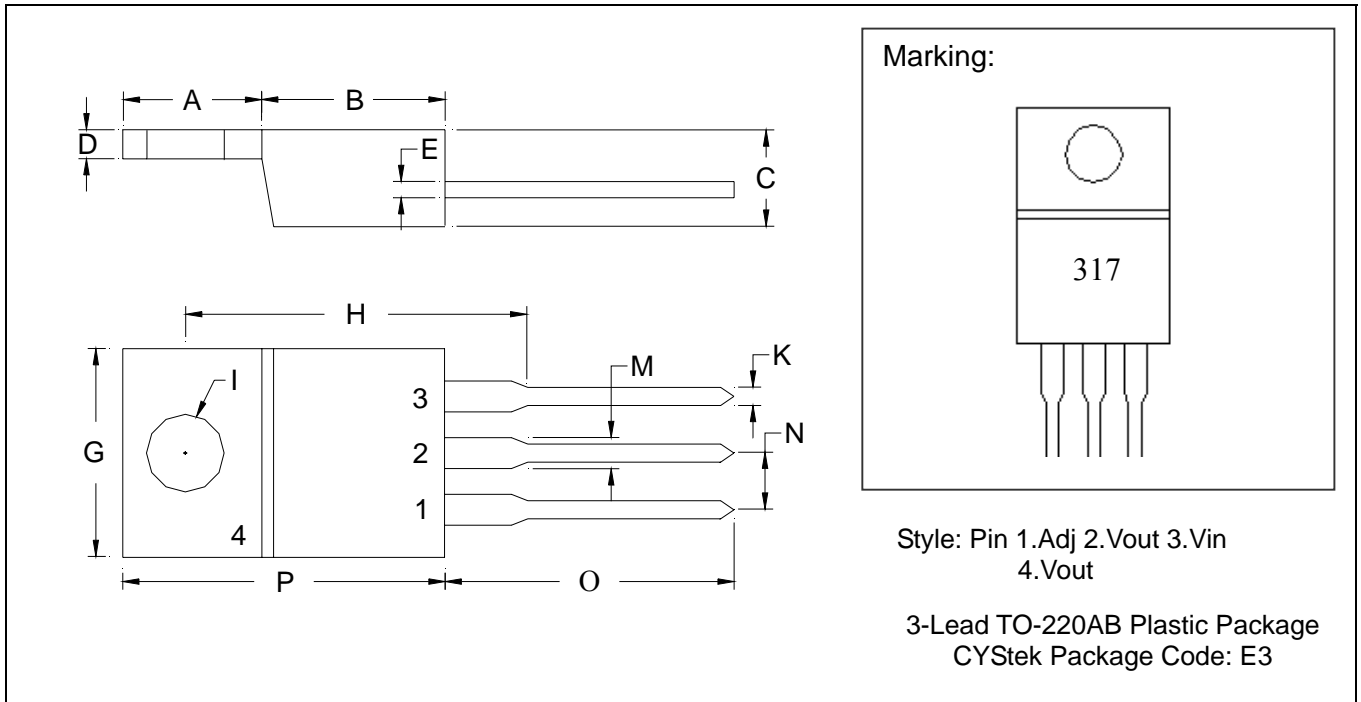

: Typical

DIM	Inches		Millimeters		DIM	Inches		Millimeters	
	Min.	Max.	Min.	Max.		Min.	Max.	Min.	Max.
A	0.2197	0.2949	5.58	7.49	I	-	*0.1508	-	*3.83
B	0.3299	0.3504	8.38	8.90	K	0.0295	0.0374	0.75	0.95
C	0.1732	0.185	4.40	4.70	M	0.0449	0.0551	1.14	1.40
D	0.0453	0.0547	1.15	1.39	N	-	*0.1000	-	*2.54
E	0.0138	0.0236	0.35	0.60	O	0.5000	0.5618	12.70	14.27
G	0.3803	0.4047	9.66	10.28	P	0.5701	0.6248	14.48	15.87
H	-	*0.6398	-	*16.25					

Notes: 1.Controlling dimension: millimeters.
 2.Maximum lead thickness includes lead finish thickness, and minimum lead thickness is the minimum thickness of base material.
 3.If there is any question with packing specification or packing method, please contact your local CYStek sales office.

Material:

- Lead: Pure tin plated.
- Mold Compound: Epoxy resin family, flammability solid burning class: UL94V-0

Important Notice:

- All rights are reserved. Reproduction in whole or in part is prohibited without the prior written approval of CYStek.
- CYStek reserves the right to make changes to its products without notice.
- CYStek **semiconductor products are not warranted to be suitable for use in Life-Support Applications, or systems.**
- CYStek assumes no liability for any consequence of customer product design, infringement of patents, or application assistance.