

SPECIFICATION FOR APPROVAL

CUSTOMER:	MODEL: EI19*6.5	DATE:	REV: A1
CUSTOMER MODEL:	PLS P/N0: E19互感器 (CT19-500T)		

1. PHYSICAL DIMENSION (UNIT:m/m) : (外型尺寸)

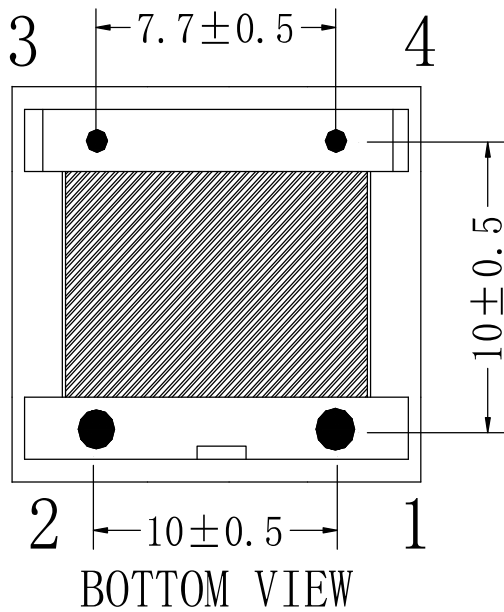
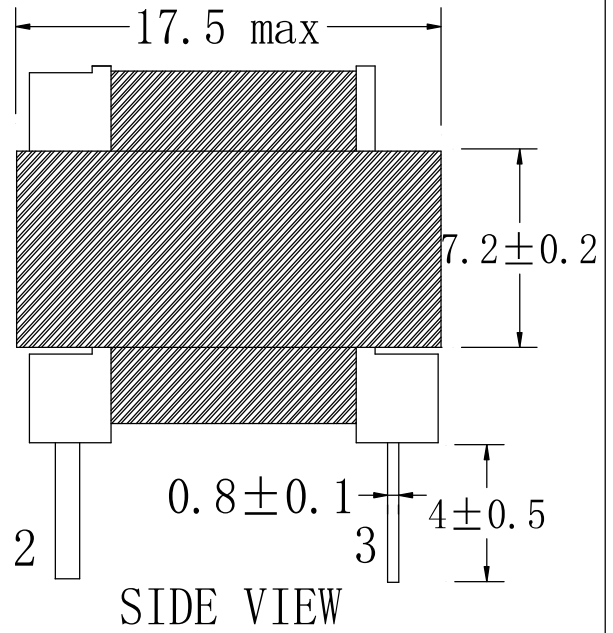
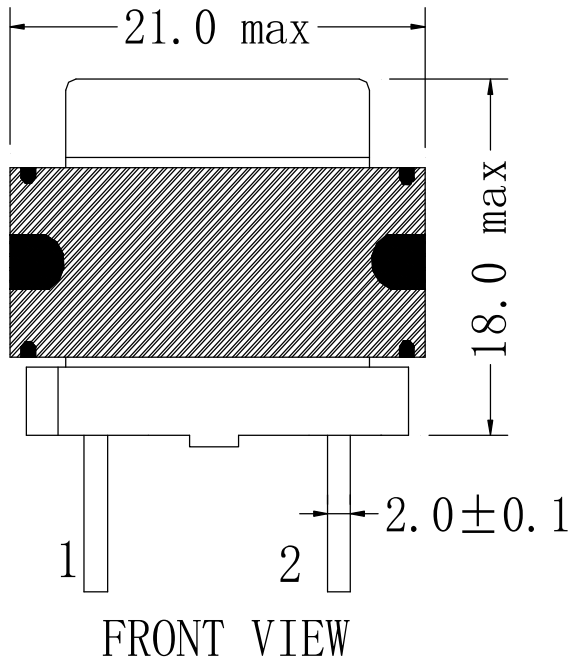

2. APPLICATION CIRCUIT (原理图)

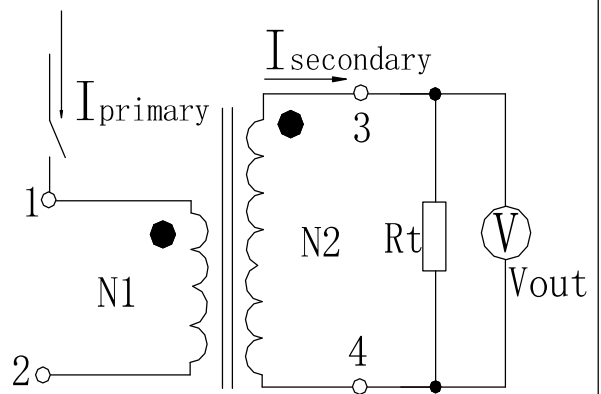

绕组N1为U型针值入骨架

APPROVED BY:	CHECKED BY:	DRAWN BY:
--------------	-------------	-----------

SPECIFICATION FOR APPROVAL

CUSTOMER:	MODEL: EI19*6.5	DATE:	REV: A1
CUSTOMER MODEL:	PLS P/NO: E19互感器 (CT19-500T)		

3. WINDING CUNSTRUCTION: (绕线结构)

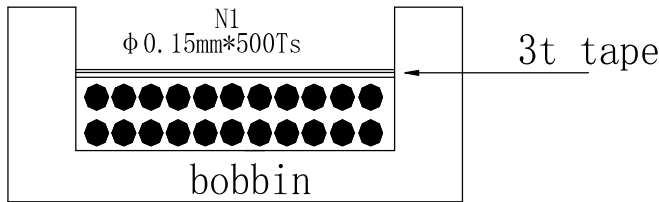

4. WINDING :

WDG NO. (组别)	PIN (脚位) S - F	Wire & Wire Copper (线径×股数)	Turns (圈数)	Winding Tape (绕线方式)	Tape Layer (胶带层次)
N2	3 - 4	2UEW-B $\phi 0.16\text{mm} * 1\text{P}$	500Ts	密绕	3ttape
N1	1 - 2	$\phi 2.0\text{mm}$ 紫铜线	1Ts	植入骨架	———

5. ELECTRICAL CHARACTERISTICS (电气参数)

5-1. INDUCTANCE: at: 1KHz 0.25V LCR1062

L3-4: 200mH $\pm 20\%$

5-2. DC RESISTANCE: at: 20°C CH-502A

R3-4: $\Omega \pm 20\%$

5-3. DIELECTRIC STRENGTH: CH-9053

COIL TO COIL 1.5KVAC 5mA FOR 60SEC

COIL TO CORE 1.5KVAC 5mA FOR 60SEC

6. MATERIAL LIST (材料表)

NO.	Name	Description	Rating	Approval	Maker
1	BOBBIN	PHENOLIC 94V-0 T375J or T355J EI19*6.5 (2P+2.0U型PIN 1G)	130°C	E59481(S)	CHANG CHUN or EQUIV
2	CORE	SILICON STEEL SHEET EL19 Z11 0.35A			DONGJUN or EQUIV
3	WIRE	POLYURETHANE ENAMELLED COPPER WIRE 2UEW	155°C	E221719	ZHEJIANG HONGBO TECHNOLOGY or EQUIV
4	CASE				YUHE METAL or EQUIV
5	TAPE	POLYESTER TAPE FILM TAPE#1350F or #371F (YELLOW)	130°C	E328315	SHENZHEN XINHUAHUI or EQUIV

APPROVED BY:	CHECKED BY:	DRAWN BY:
--------------	-------------	-----------