

# SPECIFICATION FOR APPROVAL

CUSTOMER:	PART NO: T251513C	DATE:
PART NAME: CHOKE COIL		BF REV: A

## 1. CONFIGURATION&DIMENSIONS(UNIT:mm)

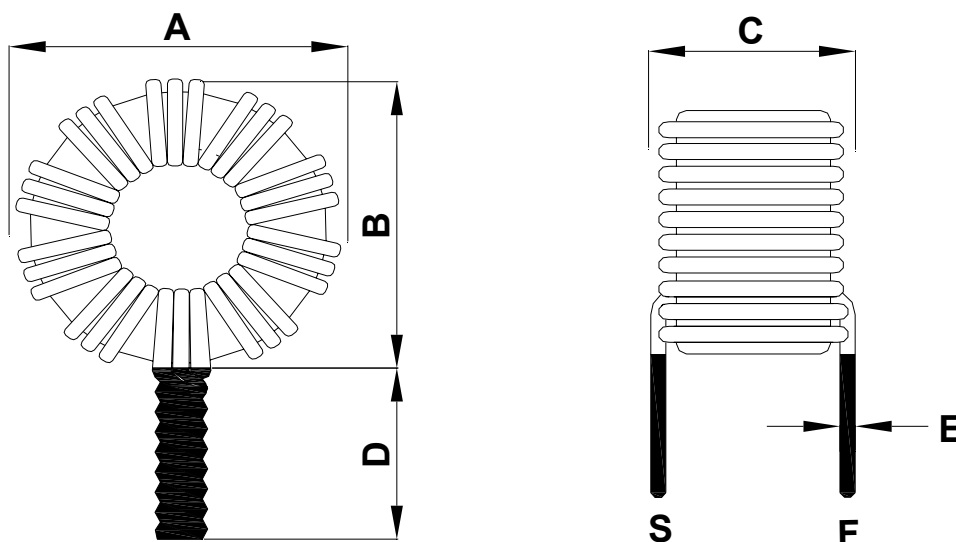

### NOTE:

1. 产品作业全程须为无铅制程。
2. 绕线时为三线并绕，出线须绞合焊锡，如图所示。
3. 测试以感量为准，圈数参考。
4. 产品不用上凡立水，含浸处理。

A: 32.0 MAX

B: 28.0 MAX

C: 20.0 MAX

D: 15.0 +/-1.0

E: 2.0 +/-0.2

## 2. ELECTRICAL CHARACTER:

(1).INDUCTANCE: 1KHZ / 0.25V (仪器: HP-4263B)

L(S-F):1.5mH+/-25%

(2). DC RESISTANCE: AT 25

DCR(S-F):7.0mΩ MAX

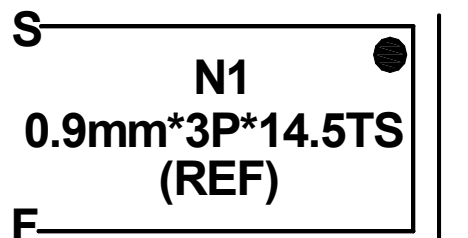

# SPECIFICATION FOR APPROVAL

<b>CUSTOMER:</b>	<b>PART NO: T251513C (GP)</b>	<b>DATE:</b>
<b>PART NAME : CHOKE COIL</b>		<b>BF REV: A</b>

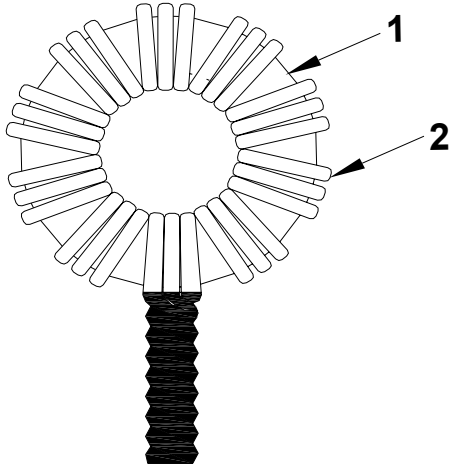

1. CORE: T25\*15\*13C      A05/R5K
2. WIRE: N1(S-F): 0.90mm\*3P\*14.5TS (REF)

### 3.MATERIAL LIST:

NO	ITEM	MATERIAL	SUPPLIER	U.L. NO.	REMARKS
1	CORE T25*15*13C	FERRITE      A05	ACME CO.,LTD		V
		FERRITE      R5K	VAKOS CO.,LTD		
2	MAGNET WIRE	POYURE THANE ENAME- LIED COPPER WIRE 2UEW 130	JUNG SHING WIRE CO.,LTD.	E174837(S)	V
3	SOLDERING	CN900-05	CHERNAN MERAL INDUSTRIAL CORP		V